

Electrified Locks

CX-EPD1289L

Electric Preload RIM Strike

INSTALLATION INSTRUCTIONS

THIS PACKAGE INCLUDES:

- | | | |
|---------------------------------|------------------------------|-----------------|
| 2 - 4-PIN power connector | 4 - 1/4 - 20 x 1-1/4" Screws | 1 - Cover plate |
| 1 - 3-PIN door status connector | 4 - M3 x 6 Screws | |
| 1 - Installation Jig | 1 - MOV | |

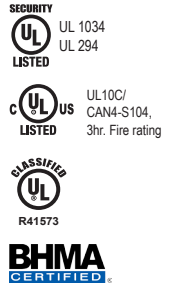

1. GENERAL DESCRIPTION

Camden CX-EPD1289L Preload RIM strike for pullman latches offers the very best strike quality and performance. The strike design delivers unparalleled application flexibility, with field selectable voltage, fail safe/fail secure operation and mechanical adjustment of the strike body.

2. SPECIFICATIONS

Voltage	12/24V AC/DC
Current Draw	560mA @ 12VDC 280mA @ 24VDC
Static Strength	1,500lbs.
Dynamic Strength	70 ft.-lbs.
Preload (Fail-Secure Only)	15lbs.
Endurance	1,000,000 Cycles (Factory Tested) 500,000 Cycles (UL Verified)
Latch Projection	3/4"
Fire Rating	UL 10C/CAN4-S104 3 hrs. (Fail Secure Only)
Mode	Field Selectable Fail Safe/Fail Secure
Mechanical Adjustment	Strike Body
Operation	AC-Buzz, DC-Silent
Duty	Continuous
Latch Bolt Monitor	SPDT, 100mA @ 24V DC Resistive
Dimensions (Body)	9-3/16"H x 1-15/16"W x 3/4"D (233mm x 49mm x 20mm)
Approvals	UL Listing #BP10200 for UL 1034 & UL 294 BHMA Certified ANSI A156.31
UL 294 Performance Levels	<ul style="list-style-type: none"> Line Security = Level I Attack Level = Level I Endurance Level = Level IV Standby Power = Level I

Windstorm Resistant

LATCHING HARDWARE IN ACCORDANCE WITH ANSI/SOI A250.13

TESTING AND RATING OF SEVERE WINDSTORM RESISTANT COMPONENTS FOR SWINGING DOOR ASSEMBLIES

*ALSO CLASSIFIED IN ACCORDANCE WITH ASTM E330, ASTM E1886, ASTM E1996, TAS 201, TAS 202, and/or TAS 203

3. DIMENSIONS

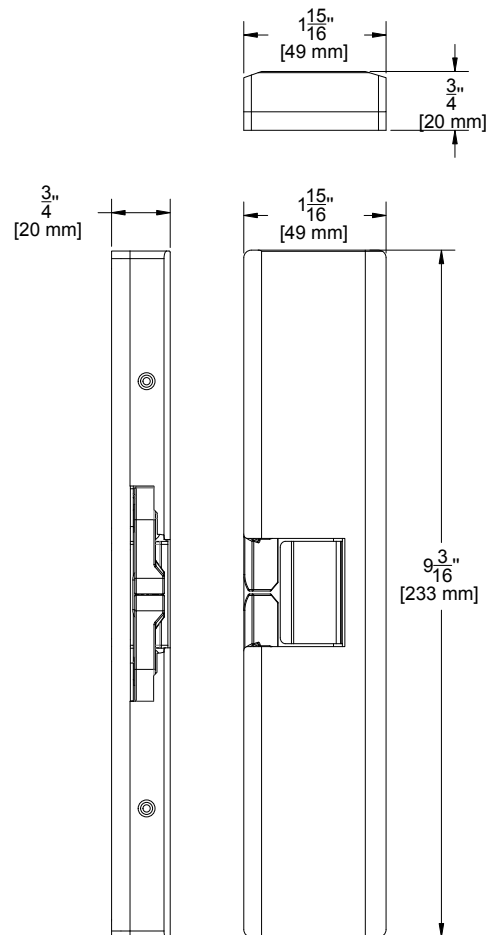

Figure 3.1 Dimensions

CX-EPD1289L Electric Preload RIM Strike

INSTALLATION INSTRUCTIONS

4. INSTALLATION

NOTICE:

The products are intended to be installed in accordance with the installation wiring diagram, mechanical assembly drawings provided with each product, the local authority having jurisdiction (AHJ) and the National Electric Code, NFPA 70. When installed in fail lock mode, the local authority shall be consulted with regard to the use of possible panic hardware to allow emergency exit from the secure area.

The electric door strike shall be installed in such a way and in such a location so as to not impair the operation of an emergency exit device or panic hardware mounted on the door.

Rim electric strikes, for use with Rim exit devices with Pullman latches, differ significantly from the installation process of electric strikes for cylindrical or mortise lock sets, necessitating additional considerations and an alternative installation approach.

To simplify the installation process, please follow the steps outlined below:

Location Marking Using Installation Template:

1. Ensure the appropriate distance between the crash bar (on the door leaf) and the rim strike (on the door jamb) is within 1/16" - 1/8" (approximately 1.5 - 3mm). If the distance exceeds, install provided 1/8" spacer plates on the door frame first. Refer to figures (a) and (b) below.

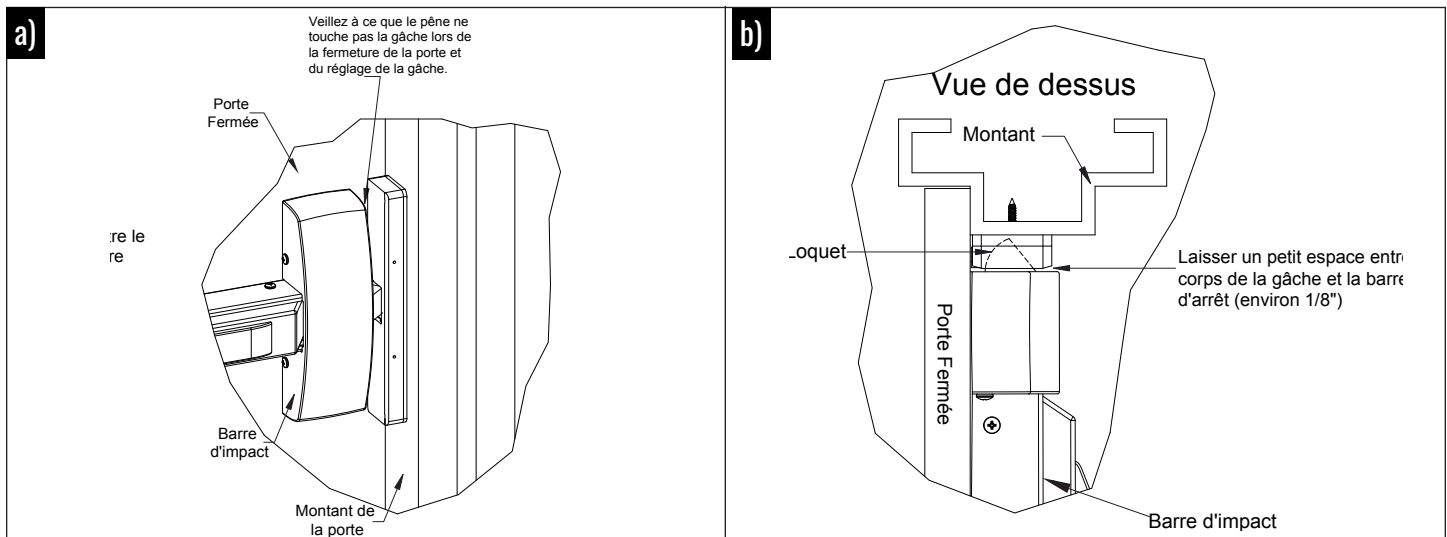

2. Before fixing the strike, use template to mark the latch's centerline on the door jamb as a reference point. Open the door slightly and align the template with the jamb edge; see figure c. Close the door, ensuring the template stays in place. Align the crash bar's latch with the template's latch hole. See figure d.

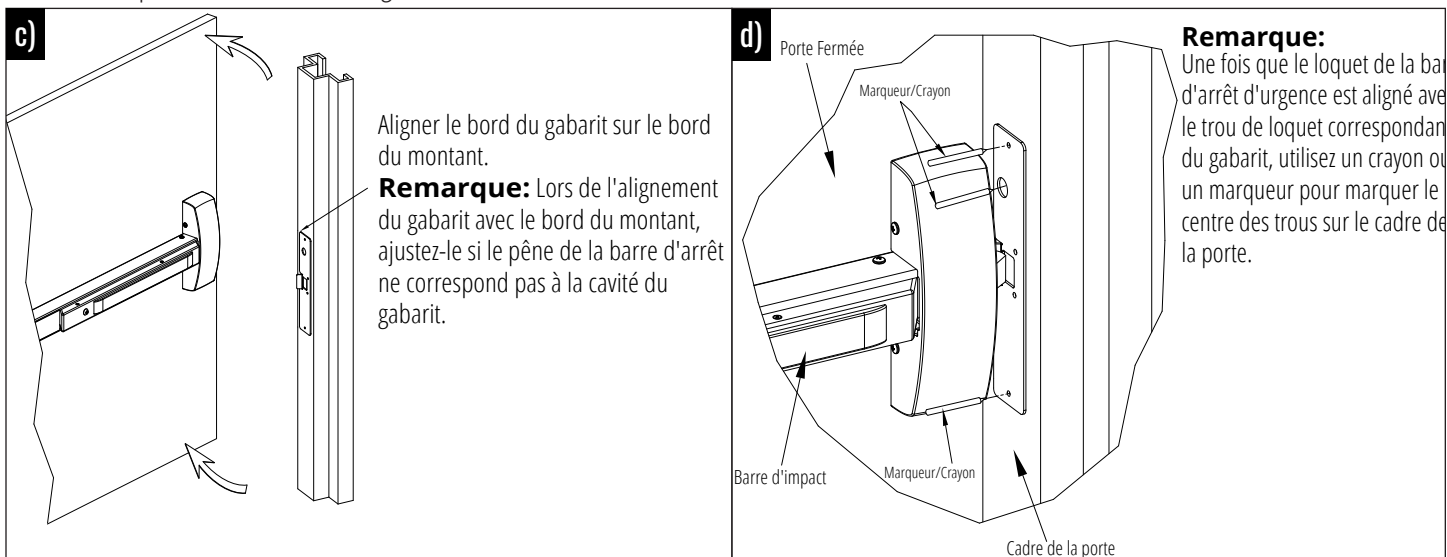

3. Open the door to remove the template and punch pilot holes at the marked locations. See figures e and f.
4. Drill a $\varnothing 9/16''$ wiring hole (indicated by letter B) and $\varnothing 7/32''$ mounting holes (indicated by letter A).

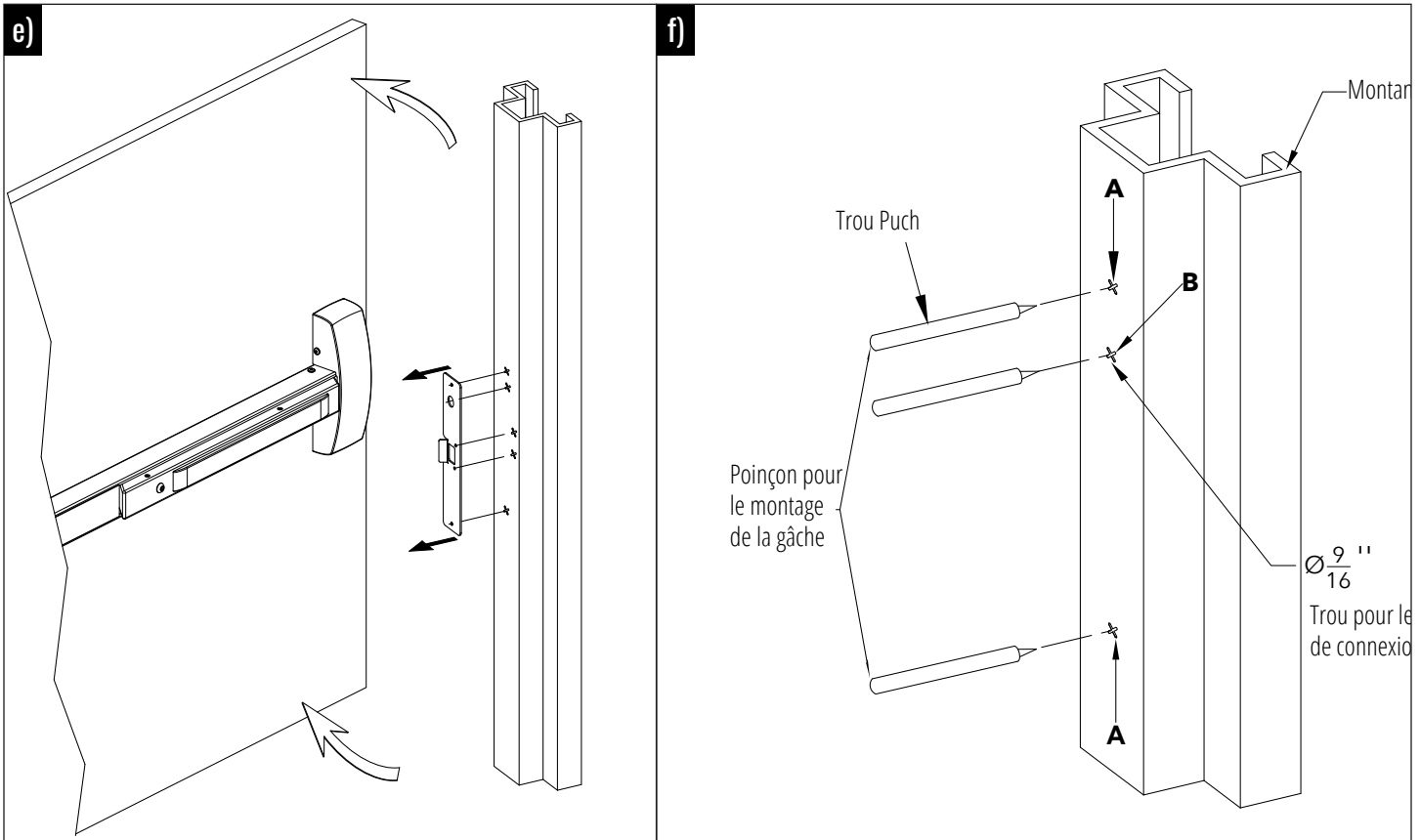

Fixing the Strike

5. Gently insert wires into the wiring hole, avoiding pulling or pinching them. Mount the rim strike on the door jamb using two 1/4 - 20 x 1-1/4" tap hexagon socket cap screws in the top and bottom mounting holes. Do not tighten them yet; see figure g.
6. Ensure the strike aligns with the jamb edges. Adjust the strike horizontally to match the vertical face of the strike with the jamb edge. See figure h.

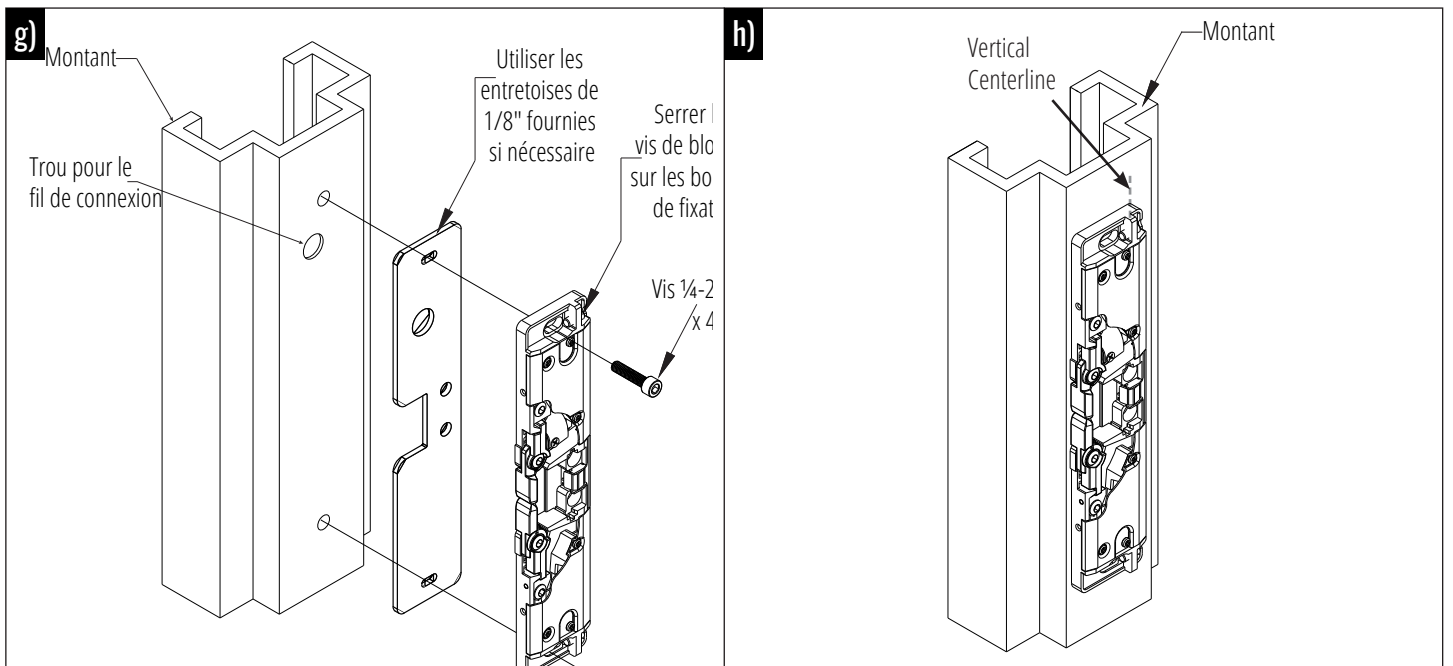

CX-EPD1289L Electric Preload RIM Strike

INSTALLATION INSTRUCTIONS

7. Once perfectly aligned, punch pilot holes in the middle, remove the strike, and drill $\varnothing 7/32$ " mounting holes. See figure i.
8. Before finalizing the installation, ensure the strike is properly connected by following the wiring instructions below:
 - a. Firstly, verify that voltage required to operate the strike is compatible with supply voltage of the installation.
 - b. Select the appropriate pre-wired power connector for the installation. When connecting the stripped ends to the supply line, insert the Metal Oxide Varistor (MOV) across the positive and negative terminals to protect the strike from voltage spikes. If required, you can cut the connector off and hardwire the strike. Refer to Figure J for wiring information and MOV connections.

Power	Varistor Connection	
	+ve end	-ve end
12V	Red/Black	Blue/Green
24V	Red	Green

Door Status Sensor
(Closed Position)
White = N/O
Orange = COM
Grey = N/C

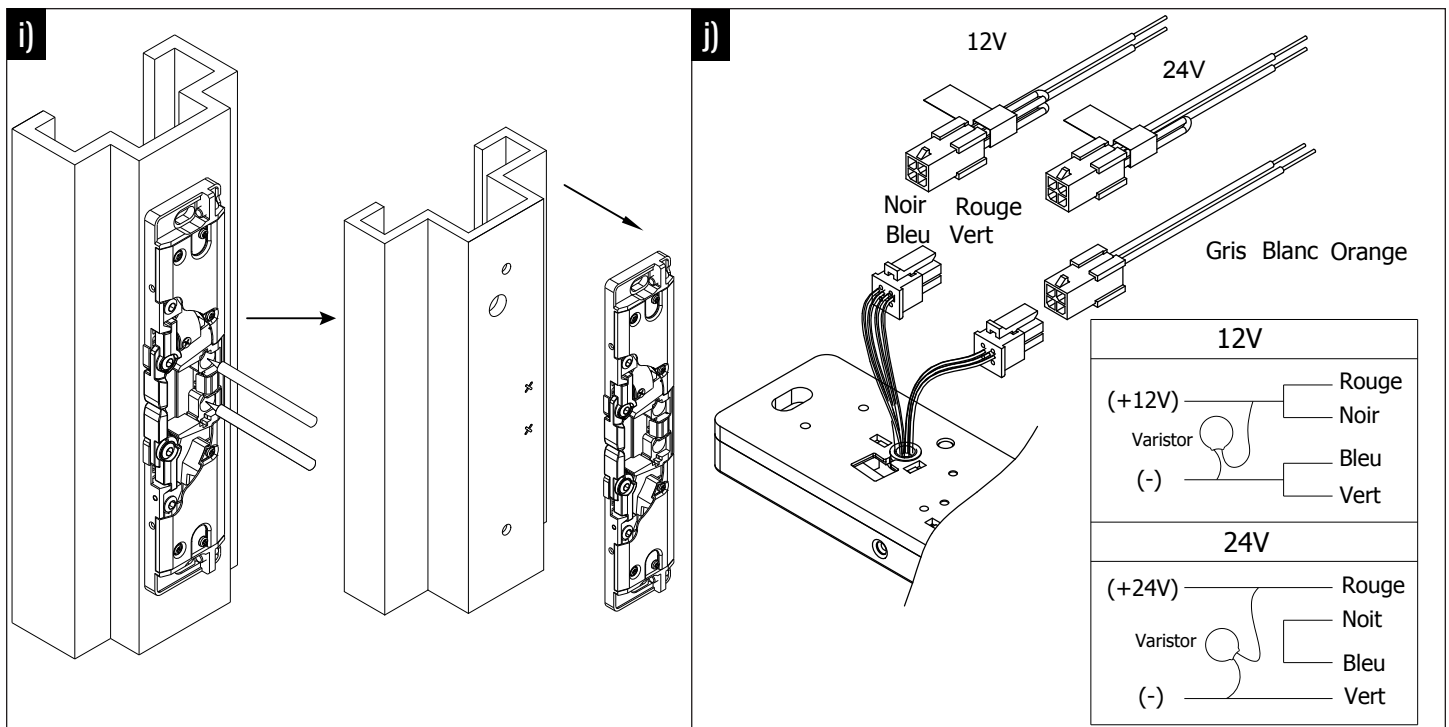

9. To finalize installation, secure the strike with all four $1/4$ " - 20 x $1-1/4$ " hex socket cap screws. Additionally, attach the latch monitor and cover the strike with the cover plate using four M3 x 6 screws. Refer to Figure k for visual guidance.

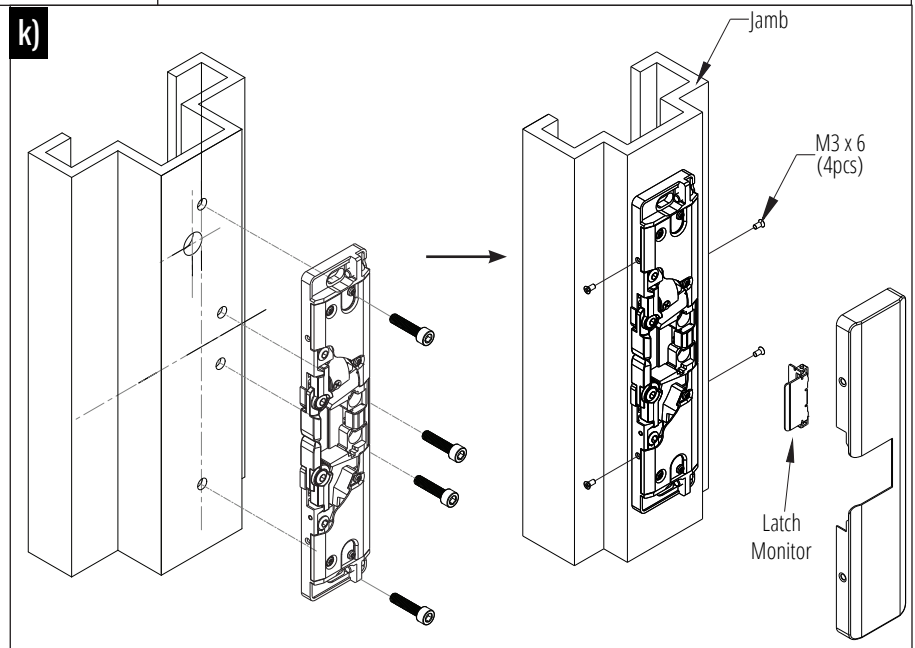

5. OPERATION

The CX-EPD1289L is set to Fail-Secure by default. To change to Fail-Safe, follow the instructions below:

1. Remove the cover plate. Remove the 6 screws at the front of the electric strike as per the diagram below.
2. Rotate status mechanism 180 degree to change operation mode.

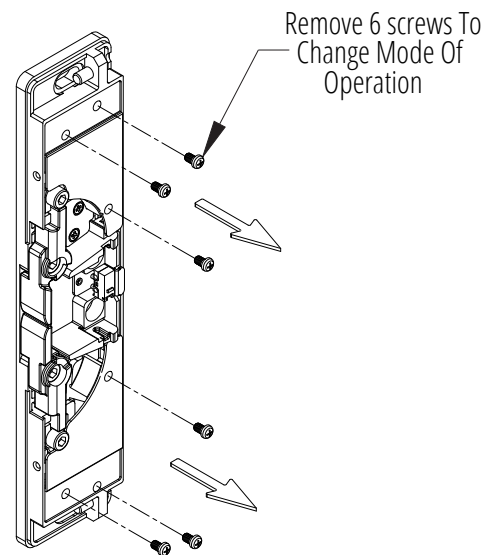
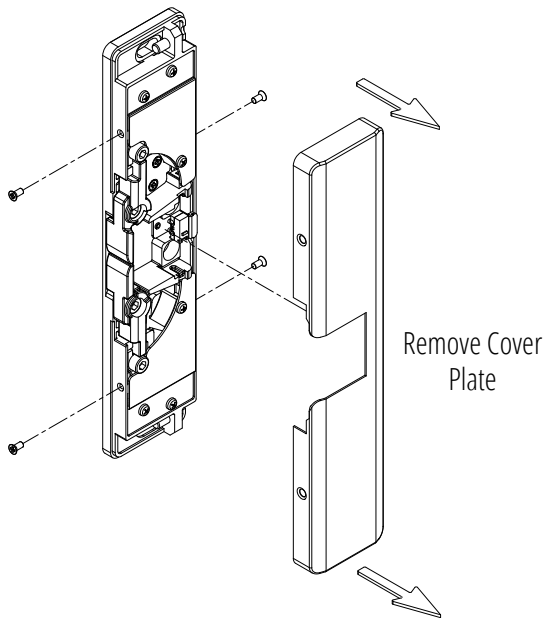

Fail-Secure Type

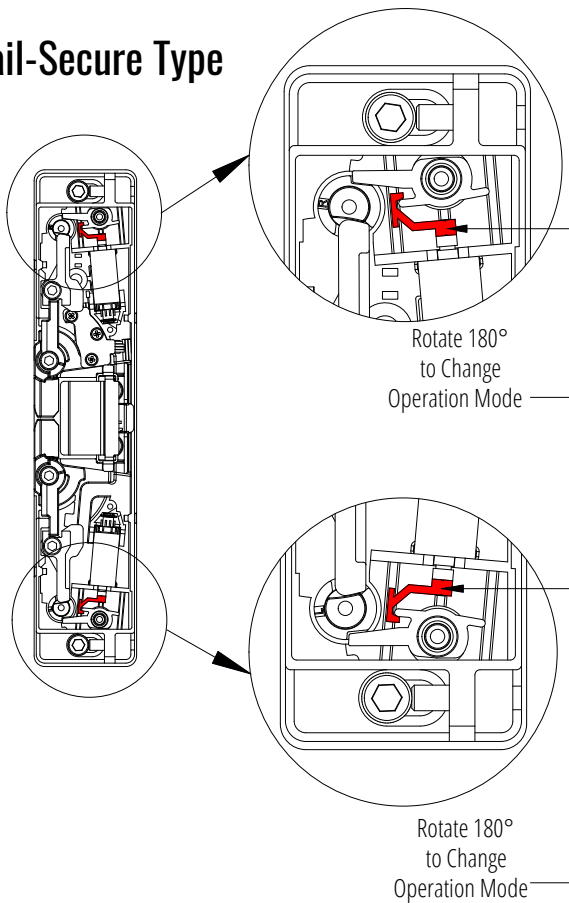

Fail-Safe Type

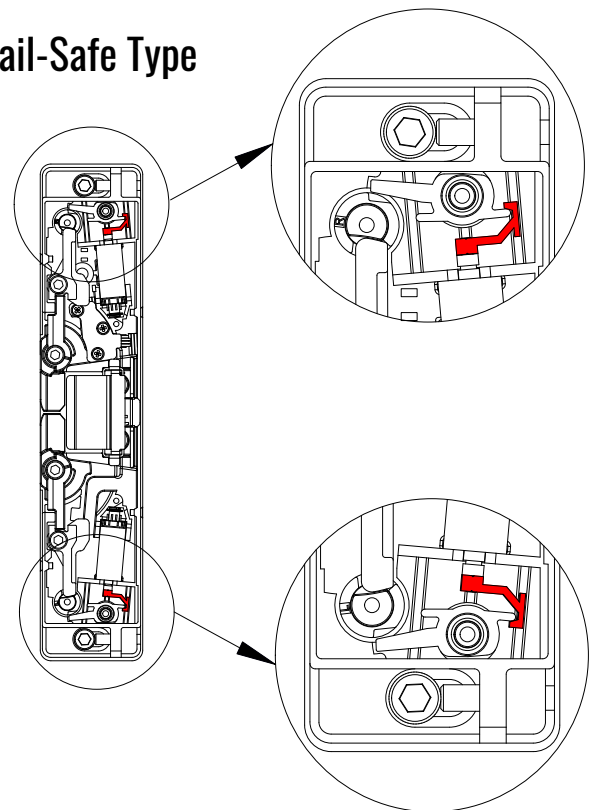

6. TROUBLESHOOTING

This guide has been produced to help installers understand the most important physical considerations that need to be addressed when installing the CX-EPD1289L.

Step 1 – Confirm Latch entry to rim strike

The position of the latch held by the rim strike is of critical importance to the operation of the strike. The most important considerations, and potential causes of failure, are as follows:

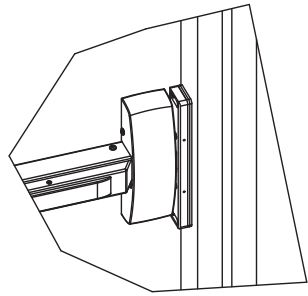

The centerline of the keeper (jaws) of the rim strike **MUST** line up with the centerline of the latch of the crash bar.

Mark the centerline of the latch on the door frame, prior to mounting the strike, to provide a point of reference.

Minimizing Preload with the CX-EPD1289L for Optimal Performance. The CX-EPD1289L is built to handle the issue of doors putting too much pressure on the lock mechanism, a problem seen in many door setups. To get the best performance, it's still important to adjust the door and its frame so there's hardly any pressure (preload) at all. This helps the system work smoothly and last longer.

Step 2 – Confirm Door Alignment

Virtually all of Camden's electric strike models, including the CX-EPD1289L, offer horizontal adjustment, to compensate for doors that are misaligned with the door frame – but there is a limit to the strike adjustment.

- Check that the door is not binding on the frame. An electric strike cannot compensate for this. If present, the door hinges will need to be adjusted.

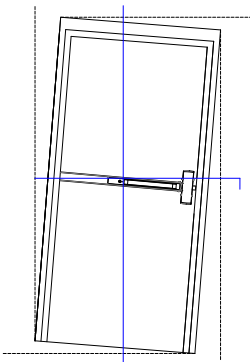

Check the gap between the door and the stop of the frame. A 1/4" difference in gap is very common and can be compensated by the strike – IF INSTALLED CORRECTLY.

If the door stop gap at the top and bottom of the door is different, The electric strike cannot be installed plumb ('straight' up and down). The horizontal

orientation of the rim strike will need to be adjusted to match the angle of the misaligned door. To do this:

- Mount the rim strike in position on the frame, using only the (2) center (elongated) screw holes, top and bottom.
- Rotate the strike until both jaws of the strike very lightly touch the crash bar latch, with equal gap, on both jaws.
- Tighten the center screws and open/close door to confirm that the latch does not bind on the jaws of the strike.
- After this is done, you can then affix all screws that permanently mount the strike on the frame.

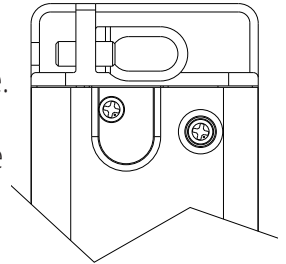

Other Considerations

Although the considerations above will address the majority of installation steps needed for a successful installation, there are additional things that you will need to check for:

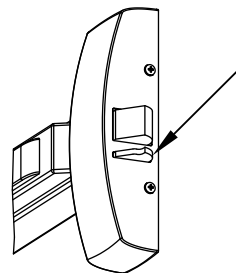

Considerations for deadlocking latch (as shown here) If the exit device has a deadlocking latch, the CX-EPD1289L must be mounted so that the deadlocking latch does not enter the latch cavity of the rim strike. Position the strike so that the deadlocking latch rests against the face of the strike.

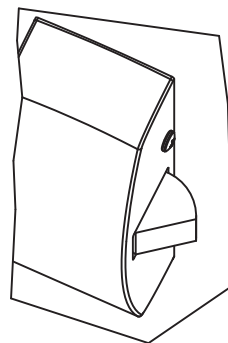

Considerations of the free movement of the exit device latch and the keeper (jaws) of the rim strike. Ensure the latch of the exit device and the keeper (jaws) of the electric strike have free and easy movement to operate together, with a minimum of friction. In this, a small amount of silicone lubricate on both the latch and jaws of the strike will improve the operation but please be careful not to over spray.

Summary

Adherence with the recommendations of this guide will avoid the most common problems associated with the installation of rim strikes. If you require additional assistance, please contact our Technical Support department by phone at 1-877-226-2269 or email support@camdencontrols.com.