

# CX-33PS

## Advanced Logic Control Relay & Power Supply Cabinet

### INSTALLATION INSTRUCTIONS



#### THIS PACKAGE INCLUDES:

- 1 - Metal Cabinet
- 1 - Pre-wired CX-33 Relay
- 1 - CX-TRX-5024 50VA Class 2 transformer
- 1 - Hardware Kit
- 1 - 2 Amp Power Supply

### 1. DESCRIPTION

The CX-33PS is designed to make installations easier and quicker by having Camden's advanced relay logic controller (CX-33) pre-wired to a color-coded set of labeled terminal strips. CX-33's 15 operating modes will handle a wide variety of applications from Vestibule openings to Card Access and Alarm Integration.

Its attractive metal cabinet also provides a pre-mounted 2 amp 12/24 VDC filtered and regulated power supply with enough current to run options such as Camden's Aura illumination boards, Emergency Call kits, and lock power. Camden CX-33PS provides a clean and organized location for field wiring. Backed by Camden's 3-year warranty.

### 3. DIMENSIONS

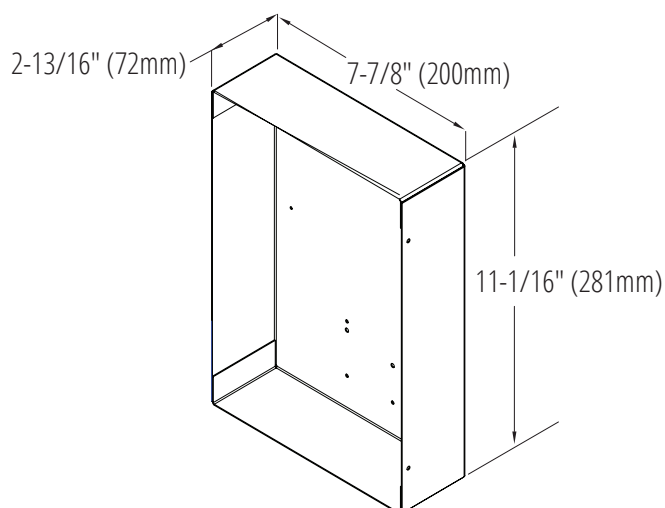

### 2. SPECIFICATIONS

Voltage	AC Input: 12V to 28V	DC Output: 12 or 24V
Current Supply	2 Amps	
Battery Backup	Gel Type Battery (not supplied)	
LED Indicator	AC and DC Output	
Temperature	Operating: 0°C to 49°C (32°F to 120°F) Storage: -20°C to 70°C (-4°F to 158°F)	
Inputs	(4) Dry, (1) Wet 5V to 120V AC/DC, Non-Polarity Optically Isolated	
Outputs	(3) Form 'C' (SPDT), 3 Amps @ 24V DC	
Time Delay	Hold 1 Timer: 0 to 50 seconds Delay 1 Timer: 0 to 15 seconds Hold 2 Timer: 0 to 50 seconds Delay 2 Timer: 0 to 60 seconds Hold 3 Timer: 0 to 50 seconds Delay on Activate: 0 to 10 seconds	
Dimensions	11-1/16" H x 7-7/8" W x 2-13/16" D (281 mm x 200 mm x 72 mm)	

### 4. INSTALLATION

**IMPORTANT:** Do not apply power to the unit until you have read the instructions fully and made the required adjustments.

#### Mounting

The CX-33PS cabinet should be mounted in a clean dry location out of direct contact with the elements.

Using a level, position the CX-33PS cabinet at the desired location and mark the four holes needed to mount it to the wall. Using the supplied wall anchors (concrete or drywall) and screws, fasten the CX-33PS to the wall.

### Wiring

**IMPORTANT:** Confirm the electrical panels breaker you are going to be using is currently off. Do not wire the primary terminals of the transformer until the secondary terminals are connected first.

Wiring the CX-33PS will be based on which one of the 15 available modes is selected to best suit your application (the modes are discussed in detail in the CX-33 installation manual). Once the mode is chosen, wiring the field devices is simplified by connecting each item to its own labeled input. There are dedicated inputs for PUSH TO OPEN/PUSH TO LOCK push plates (interior/exterior), door contacts (provides door status to the CX-33PS), dry and wet trigger inputs (for Access Control/Alarm/Fire integration), and a VAC input from the supplied step-down transformer.

There are also three Form C (SPDT) relay output terminals to connect the lock (provides lock VDC power), door operator, Aura illumination boards, and annunciators for your application. Confirming wired connections is simplified by being able to remove any field input device and testing the CX-33PS directly on its dedicated labeled terminal position.

**IMPORTANT:** Do not apply power to the unit until you have fully read the instructions and have confirmed your connections.

### General Programming Instructions

To enter the program mode, press the MENU button. The current operating mode will display. Each time you press the MENU button, the CX-33PS will advance & cycle through all menu options. These are:

Display	Description	Parameters
<b>M</b>	<b>Mode you are in</b>	<b>1-15</b>
H, then 1	Relay 1 Hold Time	0.0 to 50 Seconds
d, then 1	Relay 2 Delay Time	0.0 to 15 Seconds
H, then 2	Relay 2 Hold Time	0.0 to 50 Seconds
d, then 2	Relay 3 Delay Time	Depends on Mode
H, then 3	Relay 3 Hold Time	0.0 to 50 Seconds
d	Sets the display ON or OFF during operating mode	ON or OF
A	Input delay on Activate. If other than 0.0 is selected, then the input must be held in for the time period chosen before the CX-33 will activate.	0.0 to 10 Seconds
1	Set Dry Input 1 to activate on normally open or normally closed contact.	N/O or N/C
2	Set Dry Input 2 to activate on normally open or normally closed contact.	N/O or N/C
3	Set Dry Input 3 to activate on normally open or normally closed contact.	N/O or N/C
4	Set Dry Input 4 to activate on normally open or normally closed contact.	N/O or N/C
5	Set Wet Input 5 to activate on normally open or normally closed contact.	N/O or N/C

Use the UP and DOWN buttons to change the value of each MENU item (holding a button down will increase the scrolling speed). If you do not touch any button for 10 seconds, the CX-33PS will return to Operating Mode. If you return to Program Mode within 10 minutes, you can resume where you left off. Otherwise the program will start with the first menu item, which is Mode.

### Factory Reset (Defaulting the CX-33PS)

To return the CX-33PS back to its factory default settings you will need to remove power, then hold down the "MENU" button while powering up the CX-33PS. Once started you will see the firmware version listed then a number "1" will be displayed. Reconnect your power and press the "MENU" button once then use the "UP" or "DOWN" button to advance to the desired mode.

# CX-33PS Advanced Logic Control Relay & Power Supply Cabinet

## INSTALLATION INSTRUCTIONS

**Factory Default Values: Table 1**

Mode	Parameter											
	H1	D1	H2	D2	H3	D	A	Dry 1	Dry 2	Dry 3	Dry 4	Wet 1
1	4.0	1.0	2.0	1.5	2.0	ON	0.0	NO	NO	NO	NO	NO
2	4.0	1.0	2.0	1.5	2.0	ON	0.0	NO	NO	NC	NC	NO
3	4.0	1.0	2.0	1.5	2.0	ON	0.0	NO	NO	NC	NC	NO
4	4.0	1.0	2.0	1.5	2.0	ON	0.0	NO	NO	NO	NO	NO
5	4.0	1.0	2.0	1.5	2.0	ON	0.0	NO	NO	NO	NO	NO
6	4.0	1.0	2.0	1.5	2.0	ON	0.0	NO	NO	NO	NO	NO
7	4.0	1.0	2.0	1.5	2.0	ON	0.0	NO	NO	NO	NC	NO
8	4.0	1.0	2.0	1.5	2.0	ON	0.0	NO	NO	NO	NC	NO
9	4.0	1.0	2.0	1.5	2.0	ON	0.0	NO	NO	NO	NO	NO
10	4.0	1.0	2.0	1.5	2.0	ON	0.0	NO	NO	NO	NC	NO
11	4.0	1.0	2.0	1.5	2.0	ON	0.0	NO	NO	NO	NC	NO
12	4.0	1.0	2.0	1.5	2.0	ON	0.0	NO	NO	NO	NC	NO
13	4.0	1.0	2.0	1.5	2.0	ON	0.0	NO	NO	NO	NO	NO
14	4.0	1.0	2.0	1.5	2.0	ON	0.0	NO	NO	NO	NC	NO
15	4.0	1.0	2.0	1.5	2.0	ON	0.0	NO	NO	NO	NO	NO

### Programmable Inputs

The Dry and Wet Inputs are programmable to accept either a Normally Open or Normally Closed contact. Table 1 shows the default settings for all modes. Changes made to the inputs are saved and will remain even through a power cycle. Once the Mode is selected, changes to the inputs can be programmed. If the Mode is changed, the inputs are set to their default values for that mode. If the Mode is set back to the previous mode, all input programming changes are lost, and the default values are restored.

For example, mode is set to Mode 7. Dry 4 is reprogrammed to accept a NO contact. The mode is changed to Mode 8, then changed back to Mode 7. Dry 4 is now defaulted to accept a NC contact.

### Wet Input

Wet Input activates at 4.5V AC/DC and deactivates at 2.8V AC/DC. Some older telephone entry panels outputting wet signals do not typically reduce output to 0V when inactive. There is typically a stray voltage that can exceed 3V which does not deactivate the Wet Input. In these cases, please use the provided 50Ω, 1Watt resistor in series with the Wet Input.

### Section 3

#### Set-up Instruction Applications:

Mode 1	3-Relay Switching Network	Section 3A	Page 4
Mode 2	2-Door Airlock (Timed)	Section 3B	Page 4
Mode 3	2 Door Airlock (Latching)	Section 3C	Page 4
Mode 4	Bi-Directional Door sequencer with lock	Section 3D	Page 4
Mode 5	Apartment /Condo Applications	Section 3E	Page 5
Mode 6	Access Control Applications	Section 3F	Page 5
Mode 7	Restroom Control (normally unlocked)	Section 3G	Page 5
Mode 8	Restroom Control (normally locked)	Section 3H	Page 6
Mode 9	Lock-out Relay with switching network	Section 3J	Page 6
Mode 10	Low Energy S.A.M. with switching network	Section 3K	Page 6
Mode 11	Mag lock with N.O. Fire Alarm input	Section 3L	Page 7
Mode 12	Mag lock with N.C. Fire Alarm input	Section 3M	Page 7
Mode 13	Special Purpose Sequencer	Section 3N	Page 7
Mode 14	Delayed Egress Mode	Section 3P	Page 7
Mode 7	Lock-Down Mode	Section 3Q	Page 7
Mode 15	Bi-Directional with Access Control Sequenced with Access Control Input	Section 3R	Page 8
System Inspection Instructions			Page 8
Technical Specifications & Warranty			Page 8

**Section 3A****3 Relay Switching network (Mode 1)**

This mode sequences all 3 relays (in one direction), using what we call “mixed mode triggering”. Some popular applications include basic strike and operator installations, smoke evacuation, stairwell doors, or latching applications.

Refer to **Diagram 1**, (Page 9) for the following connections

For momentary devices, wire to either DRY 1 or WET 1 input terminals. Wire a maintained device to DRY 3 input to hold relay 1 (a lock for example). Wire a maintained device to DRY 2 input to hold relays 2 & 3 (ie -door operators).

Input number 4 is for latching applications. Each momentary switch closure will toggle relays 2 & 3. Once input and output connections are made, program the unit according to the General Programming Instructions on page 1, and walk-test the installation. Timing adjustments may need to be made.

If Hold time is =0, the relay doesn't turn on. If Delay time = 0, then the relay comes on immediately. For example, if you wish Relay 2 & 3 to both come on at the same time, set D2 time to zero (0.0).

In addition, you can add a “Delay-on-activate” (or nuisance delay) to this mode by setting time via Step 8 of the Program Mode. If this feature is used, any input will have to be held for at least the time indicated on the display **before** the CX-33PS will activate. If not wanted, set the time to zero (0.0).

Once the desired operation is achieved, proceed to Section 4, (Page 9) for System Inspection Instructions.

**Section 3B****2 Door Timed Airlock (Mode 2)**

Utilizing door position switches (CX-MDC or equivalent), this mode ensures that only one door in an airlock will be open at a time. Each output hold time is adjustable from 1 – 50 seconds. 3 outputs allow for one of the doors to have an electric lock and a door operator. Alternatively, the doors could have locks only and no operators.

Refer to **Diagram 2**, (Page 10) for the following connections. Wire the activating device(s) for Door #1 to DRY 1 terminals. Wire the activating device(s) for Door #2 to DRY 2 terminals. Wire the respective door contact switches to Inputs 3 & 4. (The contact circuit must be closed when the door is closed). Wire the outputs as shown. If a lock is not used, set H1 & D1 timers to zero (0.0), and Relay 1 will be ignored.

Once input and output connections are made, program the unit according to the General Programming Instructions on page 1, and walk-test the installation. Timing adjustments may need to be made.

It is NOT recommended to add the “Delay-on-activate” (or nuisance delay) feature in this mode!

Once the desired operation is achieved, proceed to Section 4, (Page 9) for System Inspection Instructions.

**Section 3C****2 Door Latching Airlock (Mode 3)**

Utilizing door position switches, (CX-MDC, or equivalent) this mode ensures that only one door in an airlock will be open at a time. Providing the opposite door is closed, one switch activation will latch open (unlock) the door, and the second activation on the same input will allow the door to close (lock). 3 outputs allow for one of the doors to have an electric lock and a door operator. (Alternatively, the doors could have locks only and no operators.)

The CX-33PS is unique in the industry because it also provides the ability to add an adjustable “Walk-away” time. If the door input has been activated but the door has not been opened, the relay will reset (re-lock). Both doors have their own respective adjustable timers. (If the time is set to zero, then this feature is disabled). Refer to **Diagram 3**, (Page 11) for the following connections.

Wire the activating device(s) for Door #1 to DRY 1 terminals.

Wire the activating device(s) for Door #2 to DRY 2 terminals.

Wire the respective door contact switches to Inputs 3 & 4.

(The contact circuit must be closed when the door is closed).

Wire the outputs as shown. If a lock is not used, set H1 & D1 timers to zero (0.0), and Relay 1 will be ignored.

Once input and output connections are made, program the unit according to the General Programming Instructions on page 1, and walk-test the installation. Timing adjustments may need to be made.

It is NOT recommended to add the “Delay-on-activate” (or nuisance delay) feature in this mode!

Once the desired operation is achieved, proceed to Section 4, (Page 9) for System Inspection Instructions.

**Section 3D****Bi-Directional Door Sequencer (Mode 4)**

This mode sequences all 3 relays in both directions, also known as bi-directional door sequencing.

A basic 2-door sequencer with just two inputs and two outputs is shown in **Diagram 4a** (Page 12). A more complex sequencer utilizing 4 switch inputs, and allowing for one door with an electric lock is shown in Diagram 4b (Page 13).

DRY 1 or WET 1 inputs sequence Relay 1 to Relay 2 to Relay 3.

DRY 2 input sequences Relay 3 to Relay 1 to Relay 2.

Input 3 only sequences Relay 1 to Relay 2, and Input 4 only activates Relay 3.

If a relay (Relay 1 for example) operation is not desired it can be turned off by setting the time delays to zero (in this example H1 & D1).

Once input and output connections are made, program the unit according to the General Programming Instructions on page 1, and walk-test the installation. Timing adjustments may need to be made.

# CX-33PS Advanced Logic Control Relay & Power Supply Cabinet

## INSTALLATION INSTRUCTIONS

In addition, you can add a “Delay-on-activate” (or nuisance delay) to this mode by setting time via Step 8 of the Program Mode. If this feature is used, any input will have to be held for at least the time indicated on the display before the CX-33PS will activate. If this feature is not wanted, set the time to zero (0.0)

Once the desired operation is achieved, proceed to Section 4, (Page 9) for System Inspection Instructions.

### Section 3 E

#### Apartment/Condo Application (Mode 5)

This application is for a switching network (or make/break relay) that controls an apartment or condo front door. When a visitor arrives and calls a tenant on the phone entry system, the tenant can “buzz down” and unlock the door for the visitor. During this operation, a courtesy switch is put into the circuit enabling the user to press the switch and open the door.

Once the lock releases, the courtesy switch is removed from the circuit. The inside switch will always unlock and open the door.

Refer to **Diagram 5**, (Page 14) for the following connections.

CX-33PS allows for dry and/or powered momentary connections to the Interphone panel (DRY 1 and WET inputs respectively). Wire the “Courtesy Switch” to DRY 2 input. Wire the inside switch to DRY 3 input. An optional Key switch can be added for use by tenants - wire to either DRY 1 (to unlock only), or DRY 3 (to unlock and open door). An optional Fire Panel Input can be connected to DRY 4. Output #1 is for the electric lock, and Output #2 is for the door operator.

Once input and output connections are made, program the unit according to the General Programming Instructions on page 1, and walk-test the installation. Timing adjustments may need to be made.

In addition, you can add a “Delay-on-activate” (or nuisance delay) to this mode by setting time via Step 8 of the Program Mode. If this feature is used, any input will have to be held for at least the time indicated on the display before the CX-33PS will activate. If this feature is not wanted, set the time to zero (0.0)

Once the desired operation is achieved, proceed to Section 4, Page 9 for System Inspection Instructions.

### Section 3 F

#### Access Control Application (Mode 6)

This application is for a control relay that takes a maintained signal and unlocks a door for an extended time. During this time, an exterior momentary switch is put into the circuit to allow the door to activate automatically. After the access system or time-clock has released the signal, the door relocks, and the exterior switch is removed from the circuit.

At any time, the inside switch will unlock and open the door. Refer to **Diagram 6**, (Page 15) for the following connections.

The CX-33PS allows for dry and/or powered maintained connections to the Access System / time clock (DRY 1 and/ or WET inputs respectively). Wire the Exterior momentary Switch” to DRY 2 input.

Wire the inside momentary switch to DRY 3 input. An optional Key switch can be added for use by tenants - wire to either DRY 1 (to unlock only), or DRY 3 (to unlock and open door). DRY 4 Input is used if you wish to connect a Fire Alarm Panel.

Output #1 is for the electric lock, and Output #2 is for the door operator. Once input and output connections are made, program the unit according to the General Programming Instructions on page 1, and walk-test the installation. Timing adjustments may need to be made.

In addition, you can add a “Delay-on-activate” (or nuisance delay) to this mode by setting time via Step 8 of the Program Mode. If this feature is used, any input will have to be held for at least the time indicated on the display before the CX-33PS will activate. If this feature is not wanted, set the time to zero (0.0)

Once the desired operation is achieved, proceed to Section 4, (Page 9) for System Inspection Instructions.

### Section 3 G

#### Normally Unlocked Restroom (Mode 7)

In this mode, control of a single occupant barrier-free washroom is obtained. It allows the user to lock and secure the door from the inside by depressing a Push-to-Lock button (once door is in the closed position). The exterior wall switch is removed electronically from the circuit.

To exit the washroom, simply exit manually via the store-room function lever-handle set (the Door Contact Switch resets the relay), or, press the interior wall switch to unlock and signal the door operator. The door remains unlocked upon closure (see Mode 8 for normally locked doors). The CX-33PS also provides a relay dedicated for “Occupied” & “Door Locked” signage.

Refer to **Diagram 7**, (Page 16) for the following connections. The outside wall switch, inside wall switch, and Push-to-Lock switch are all N.O. momentary switches. Connect as shown. The Door Contact Switch circuit must be closed when the door is closed and open when the door opens.

A fail-safe electric strike is recommended and connects to Relay 1 (although a fail-secure strike can also be used).

The automatic door operator connects to Relay 2, and the signage connects to Relay 3. (As a reminder, no power is provided on the relay outputs – they are dry contacts).

Once input and output connections are made, program the unit according to the General Programming Instructions on page 1, and walk-test the installation. Timing adjustments may need to be made.

It is NOT recommended to add the “Delay-on-activate” (or nuisance delay) feature in this mode!

Once the desired operation is achieved, proceed to Section 4, (Page 9) for System Inspection Instructions.

## Section 3 H

### Normally Locked Restroom (Mode 8)

In this mode, control of a normally locked single occupant barrier-free washroom is obtained. It allows the user to secure the door from the inside by depressing a Push-to-Lock button. The exterior means of ingress is removed electronically from the circuit.

To exit the washroom, simply exit manually via the store-room function lever-handle set (the Door Contact Switch resets the relay), or, press the interior wall switch to unlock and signal the door operator. Exiting the washroom resets the relay, and the door is re-locked upon closure.

The CX-33PS also provides a relay dedicated for "Occupied & "Door Locked" signage (recommended).

Refer to **Diagram 8**, (Page 18) for the following connections.

The outside means of ingress – Keypad, Key switch, or Prox-reader, plus the inside wall switch, and Push-to-Lock switch are all N.O. momentary devices. Connect as shown.

The Door Contact circuit must be closed when the door is closed and open when the door opens.

A fail-secure electric strike is typically used, although a fail-safe strike can also be used. Connect to Relay 1. The automatic door operator connects to Relay 2, and the signage connects to Relay 3. (As a reminder, no power is provided on the relay outputs – they are dry contacts).

As a safety feature, the door cannot be "secured" via the "Push-to-Lock" button until the door is completely closed (prevents children from pressing the lock button and running away).

Once input and output connections are made, program the unit according to the General Programming Instructions on page 1, and walk-test the installation. Timing adjustments may need to be made.

It is NOT recommended to add the "Delay-on-activate" (or nuisance delay) feature in this mode!

Once the desired operation is achieved, proceed to Section 4, (Page 9) for System Inspection Instructions.

## Section 3 J

### Lock-out Relay Plus (Mode 9)

This mode combines, for the first time, a lintel mount safety sensor lock-out relay (LOR) with a switching network (aka make/break relay). The voltage sensing circuit can be utilized with motors/controls up to 120 volts AC/DC. The adjustable hold timer (lock-out) is then matched to the door closing time. "Cancellation" inputs are provided for connection to rail-mounted door beams.

In addition, three inputs and two relays are provided for the switching network function.

Refer to **Diagram 9**, (Page 19) for the following connections.

### LOR Circuit:

A parallel connection is made to the two motor wires running from the Operator (motor) to its control. If the motor is AC, then polarity is not an issue. The CX-33PS is triggered by the AC voltage going from high to low.

If the motor is DC, then the wires are polarity sensitive. If Relay 3 LED doesn't illuminate when the door is closing, then just reverse the two terminal connections at the CX-33PS.

Input 1 is for the N.O. relay contacts of the photo beam. The beams are typically mounted at the end of guide rails and designed to reset the LOR in the event anyone should walk into the swing path when the door is in the closing cycle.

Relay 3 output is to be connected in SERIES with the safety device and the Safety Circuit of the operator.

### Optional Switching Network:

Wire the activating device(s) to DRY 1, DRY 2 or DRY 3 terminals. Wire the outputs as shown to Relays 1 & 2.

Once input and output connections are made, program the unit according to the General Programming Instructions on page 1, and walk-test the installation. Timing adjustments may need to be made.

It is NOT recommended to add the "Delay-on-activate" (or nuisance delay) feature in this mode. Once the desired operation is achieved, proceed to Section 4, (Page 9) for System Inspection Instructions.

## Section 3 K

### Low Energy SAM Plus (Mode 10)

This mode combines a Low-Energy Secondary Activation Module (SAM) with a switching network (aka make/break relay). Utilizing a door position switch input, this mode enables or disables a door mounted presence sensor. The sensor is put into the circuit when a wall switch is pressed (a Knowing Act). This allows an object or person in the path of the door to be detected. The door will not close until the object or person leaves the door swing path. The sensor remains in the circuit until the door is closed.

When the door is opened manually, the safety sensor is not in the circuit and the door operator functions as a manual door closer. A unique feature of the CX-33PS is the automatic reset feature. If a switch has been pressed, but the door has not opened within 60 seconds (because it is locked, for instance), the unit resets, reducing wear and tear on the lock and operator.

In addition, one input and two relays are provided for the switching network function.

Refer to **Diagram 10**, (Page 20) for the following connections.

### SAM Circuit:

Connect the momentary activating switch(es) to DRY 3 input. The door mounted sensor connects to DRY 2 input, and the magnetic contact switch connects to DRY 4 input. The contact switch circuit must be closed when the door is closed, and open when the door opens.

# CX-33PS Advanced Logic Control Relay & Power Supply Cabinet

## INSTALLATION INSTRUCTIONS

Relay 3 output is to be connected to the Activate circuit of the door operator.

Optional Switching Network:

Wire the activating device(s) to DRY 1 terminals.

Wire the outputs as shown to Relays 1 & 2.

Once input and output connections are made, program the unit according to the General Programming Instructions on page 1, and walk-test the installation. Timing adjustments may need to be made.

It is NOT recommended to add the "Delay-on-activate" (or nuisance delay) feature in this mode.

Once the desired operation is achieved, proceed to Section 4, (Page 9) for System Inspection Instructions.

### Section 3 L

#### Mag Lock with N.O. Fire Alarm (Mode 11)

Commonly seen in hospital corridors, this version of a switching network (make/break relay) is specifically designed for doors with mag locks.

A wall switch signals the relay, which unlocks, and opens the door for an adjustable time. Utilizing the door position switch, the CX-33PS will not re-apply power to the magnetic lock until the door is fully closed. The relay also provides for a normally open Fire Alarm input, which when activated, unlocks the door and disables the wall switch inputs.

Refer to **Diagram 11**, (Page 21) for the following connections:

Momentary switches connect to DRY 1 and/or WET terminals.

Maintained devices connect to DRY 2 input (optional).

The N.O. Fire Alarm signal is wired to DRY 3 input, and the Door Position Switch connects to DRY 4 input. The circuit must be closed when the door is closed, and open when the door opens.

The magnetic lock connects to the Common and N.C terminals of Relay 1. The door operator connects to the Common and N.O. terminals of Relay 2. Relay 3 output is optional.

Once input and output connections are made, program the unit according to the General Programming Instructions on page 1, and walk-test the installation. Timing adjustments may need to be made.

It is NOT recommended to add the "Delay-on-activate" (or nuisance delay) feature in this mode!

Once the desired operation is achieved, proceed to Section 4, (Page 9) for System Inspection Instructions.

### Section 3 M

#### Mag Lock with N.C. Fire Alarm (Mode 12)

This mode is identical to Mode 11 (Section 3L) except the Fire Alarm input is a N.C. circuit (rather than N.O.). See previous section for wiring and adjustments, & refer to **Diagram 12**, (Page 22).

### Section 3 N

#### Special Purpose Sequencer (Mode 13)

In this mode, Input 1 sequences Relays 1 & 2, Input 2 sequences Relays 2 & 3. Input 3 sequences Relays 1 - 2 - 3, and Input 4 sequences Relays 1 - 3 - 2.

Refer to **Diagram 13** (Page 23) for connections. Once input and output connections are made, program the unit according to the General Programming Instructions on page 1, and walktest the installation. Perform any timing adjustments.

In addition, you can add a "Delay-on-activate" (or nuisance delay) to this mode by setting time via Step 8 of the Program Mode. If this feature is used, any input will have to be held for at least the time indicated on the display before the CX-33PS will activate. If this feature is not wanted, set the time to zero (0.0)

Once the desired operation is achieved, proceed to Section 4, (Page 9) for System Inspection Instructions.

### Section 3 P

#### Delayed Relay Activation (Mode 14)

Refer to **Diagram 14** (Page 24) for connections. In this unique mode, a Switch connected to Input 1 will cause Relay 1 to fire immediately, but not allow Relays 2 & 3 to fire until a pre-set elapsed time has expired. The user must push and hold the switch for this length of time. A Fire alarm input is provided – DRY 2 or WET 1. A Bypass or Shunt Keyswitch is connected to DRY 3, and a N/C door position switch is connected to DRY 4.

Output 1 is for a local siren, Output 2 is for the electric lock, and Output 3 is for status monitoring.

Once connections are made, power up and adjust H1 time for the length of time switch 1 must be pressed. H2 time is the minimum ON time for Relay 2 (lock).

It is NOT recommended to add the "Delay-on-activate" (or nuisance delay) feature in this mode.

Once the desired operation is achieved, proceed to Section 4, (Page 9) for System Inspection Instructions.

Note: Not for use as UL compliant delayed egress.

### Section 3 Q

#### Lock Down Mode (Mode 7)

In this mode, during normal operation the all-active switches (both connected to Input 1) trigger the auto door operator.

When desired, a "Lock-Down" switch located remotely (in a school office for instance) will activate the door lock, and disable the door switch input. A separate output can drive a status LED / light. When the "Reset" button (connected to Input 4) is momentarily depressed the door unlocks, and the system resets.

Refer to **Diagram 7a** (Page 17) for connections. The allactive switches and Lock-down Switch are all normally open switches. The RESET switch is normally closed. Connect as shown. A fail-safe electric strike, or mag lock should be used.

Input 2 allows for an optional secure entry keypad (or similar), or connection to a fire alarm.

Once connections are made, power up and program the unit according to the General Programming Instructions on Page 1, and walk-test the installation. Adjust H1 time for the lock time, D1 for the time between the lock and operator, and H2 for the time delay for the auto door operator. D2 and H3 are not used in this mode.

It is NOT recommended to add the "Delay-on-activate" (or nuisance delay) feature in this mode.

Once the desired operation is achieved, proceed to Section 4, (Page 9) for System Inspection Instructions.

### Section 3 R

#### Bi-Directional Door Sequencer with Access Control Input (Mode 15)

This mode sequences all 3 relays in both directions, also known as bi-directional door sequencing. Refer to Diagrams 15a & 15b on pages 25 and 26.

Access control systems can be connected to the WET input to unlock the door before sequencing the operators. The door remains unlocked while there is a maintained signal on the WET input.

DRY1 input is only active while there is signal on the WET input.

DRY 1 input sequences Relay 1 to Relay 2 to Relay 3.

DRY 2 input sequences Relay 3 to Relay 1 to Relay 2.

DRY 2 input will always unlock the door before sequencing Input 3 only sequences Relay 1 to Relay 2, and Input 4 only activates Relay 3.

If a relay (Relay 1 for example) operation is not desired it can be turned off by setting the time delays to zero (in this example H1 & D1).

Once input and output connections are made, program the unit according to the General Programming Instructions on page 1 and walk-test the installation. Timing adjustments may need to be made.

In addition, you can add a "Delay-on-activate" (or nuisance delay) to this mode by setting time via Step 8 of the Program Mode. If this feature is used, any input will have to be held for at least the time indicated on the display before the CX-33PS will activate. If this feature is not wanted, set the time to zero (0.0)

Once the desired operation is achieved, proceed to Section 4, (Page 9) for System Inspection Instructions.

### Section 4

#### System Inspection Instructions

After the Installation and operational check of the system:

1. Place any applicable labels on the door (as per ANSI A156.10 or A156.19 guidelines).
2. Instruct the owner on door system operation and how to walk-test it. This should be checked on a daily basis.
3. Instruct the owner on what to do if the door or any of its components become damaged.
4. Strongly recommend to the owner that the complete entry be inspected twice a year as part of the service agreement, or at least once per year as per AAADM guidelines.

### Section 5

#### Warranty

Camden Door Controls guarantees the CX-33PS to be free from manufacturing defects for 3 years from date of sale.

If during the first 3 years the CX-33PS fails to perform correctly, it may be returned to our factory where it will be repaired or replaced (at our discretion) without charge.

Except as stated herein, Camden extends no warranties expressed or implied regarding function, performance or service.

# CX-33PS Advanced Logic Control Relay & Power Supply Cabinet

## INSTALLATION INSTRUCTIONS

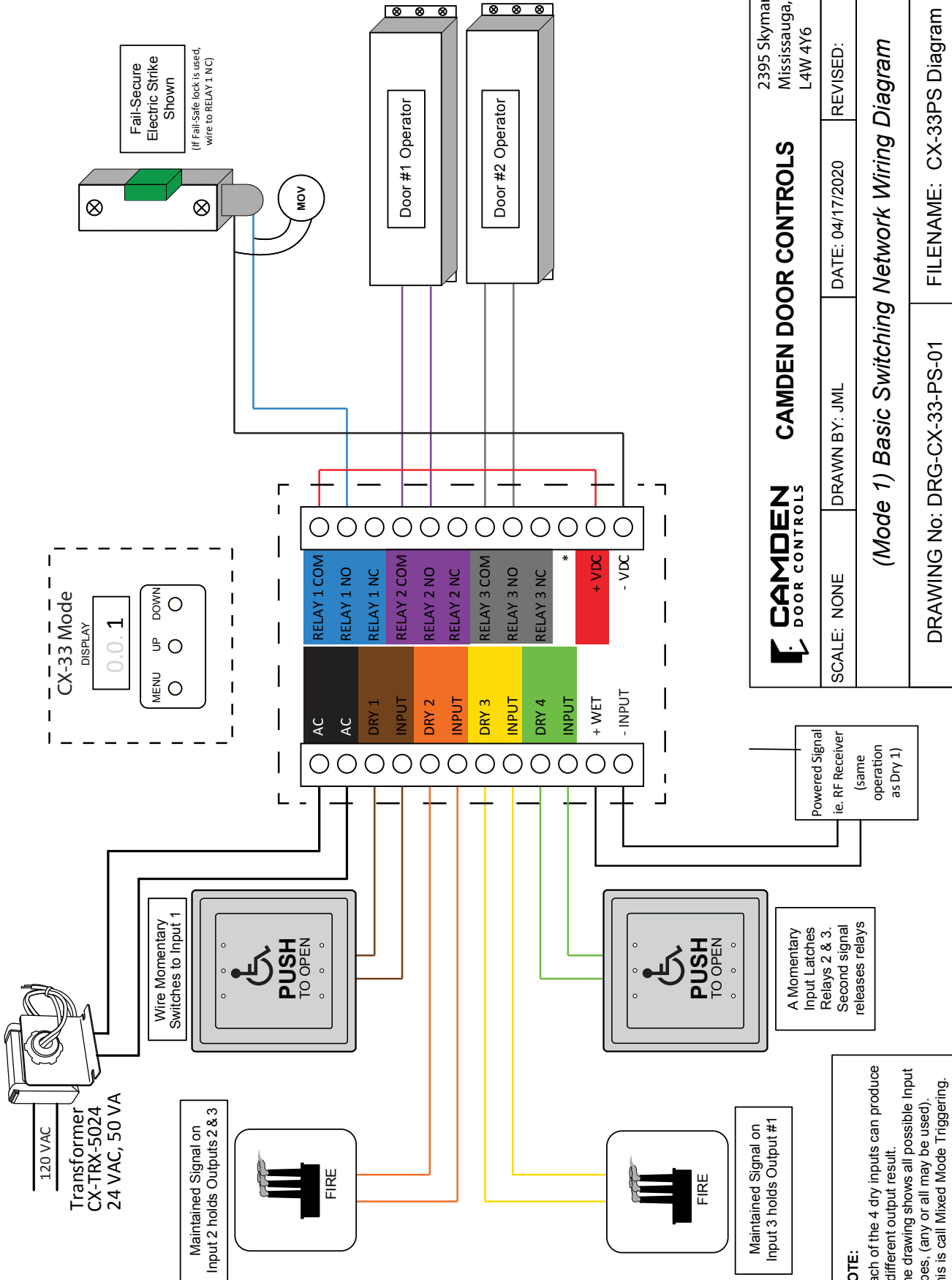

**CAMDEN DOOR CONTROLS**

2395 Skymark Ave,  
Mississauga, ON  
L4W 4Y6

SCALE: NONE

DRAWN BY: JML

DATE: 04/17/2020

REVISED:

### (Mode 1) Basic Switching Network Wiring Diagram

DRAWING No: DRG-CX-33-PS-01

FILENAME: CX-33PS Diagram 1.ai

# CX-33PS Advanced Logic Control Relay & Power Supply Cabinet

## INSTALLATION INSTRUCTIONS

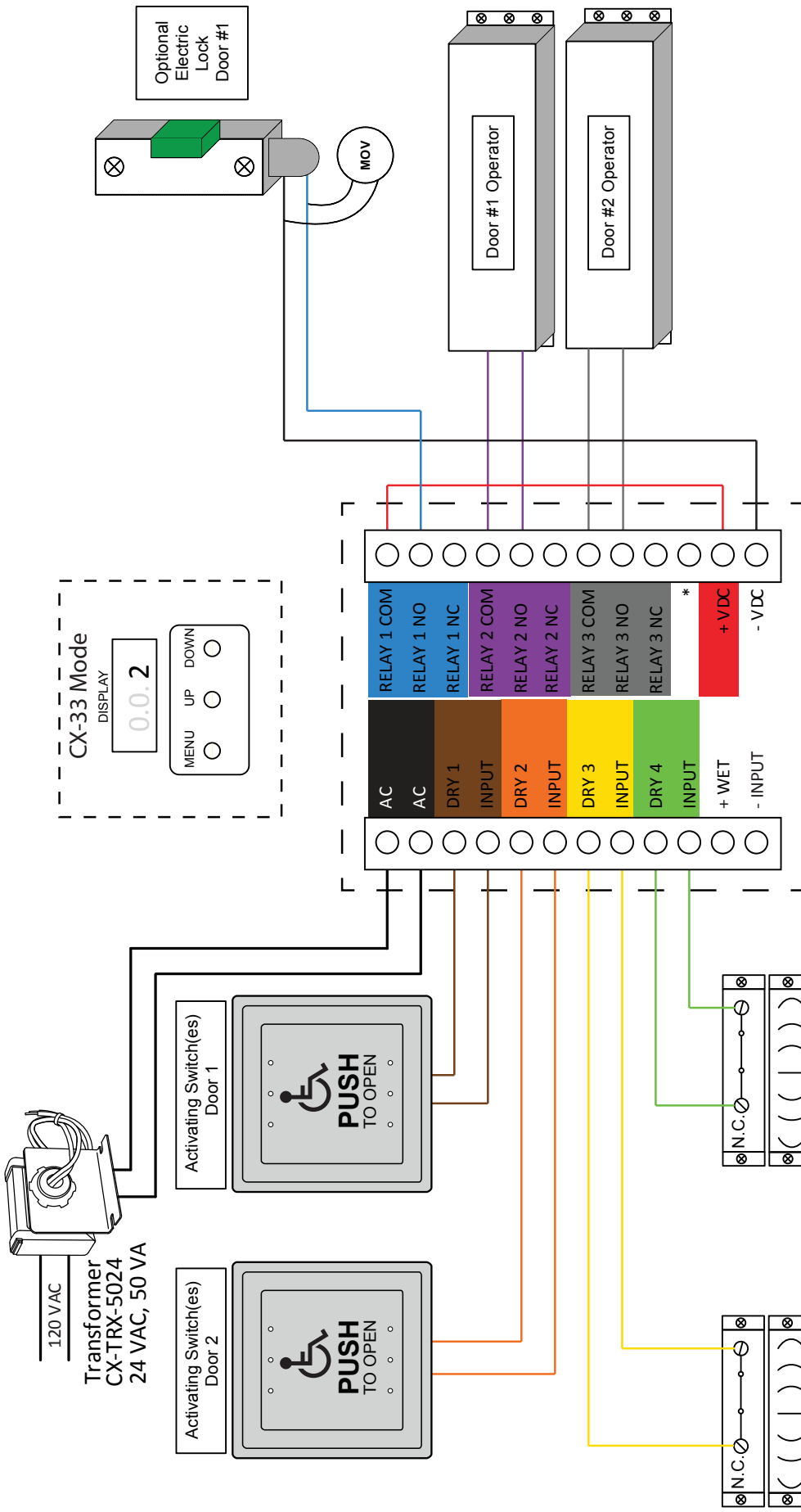

**CAMDEN DOOR CONTROLS**  
 2395 Skymark Ave,  
 Mississauga, ON  
 L4W 4Y6

SCALE: NONE

DRAWN BY: JML

DATE: 04/17/2020

REVISED:

*(Mode 2) 2 Door Timed Airlock Wiring Diagram*

DRAWING No: DRG-CX-33-PS-02

FILENAME: CX-33PS Diagram 2.ai

- NOTE:**
1. Door Contact circuit must be closed when door is closed, and open when door opens.
  2. If electric lock is not used, set H1 and D1 timers to 0.D2 is not used in this mode.

# CX-33PS Advanced Logic Control Relay & Power Supply Cabinet

## INSTALLATION INSTRUCTIONS

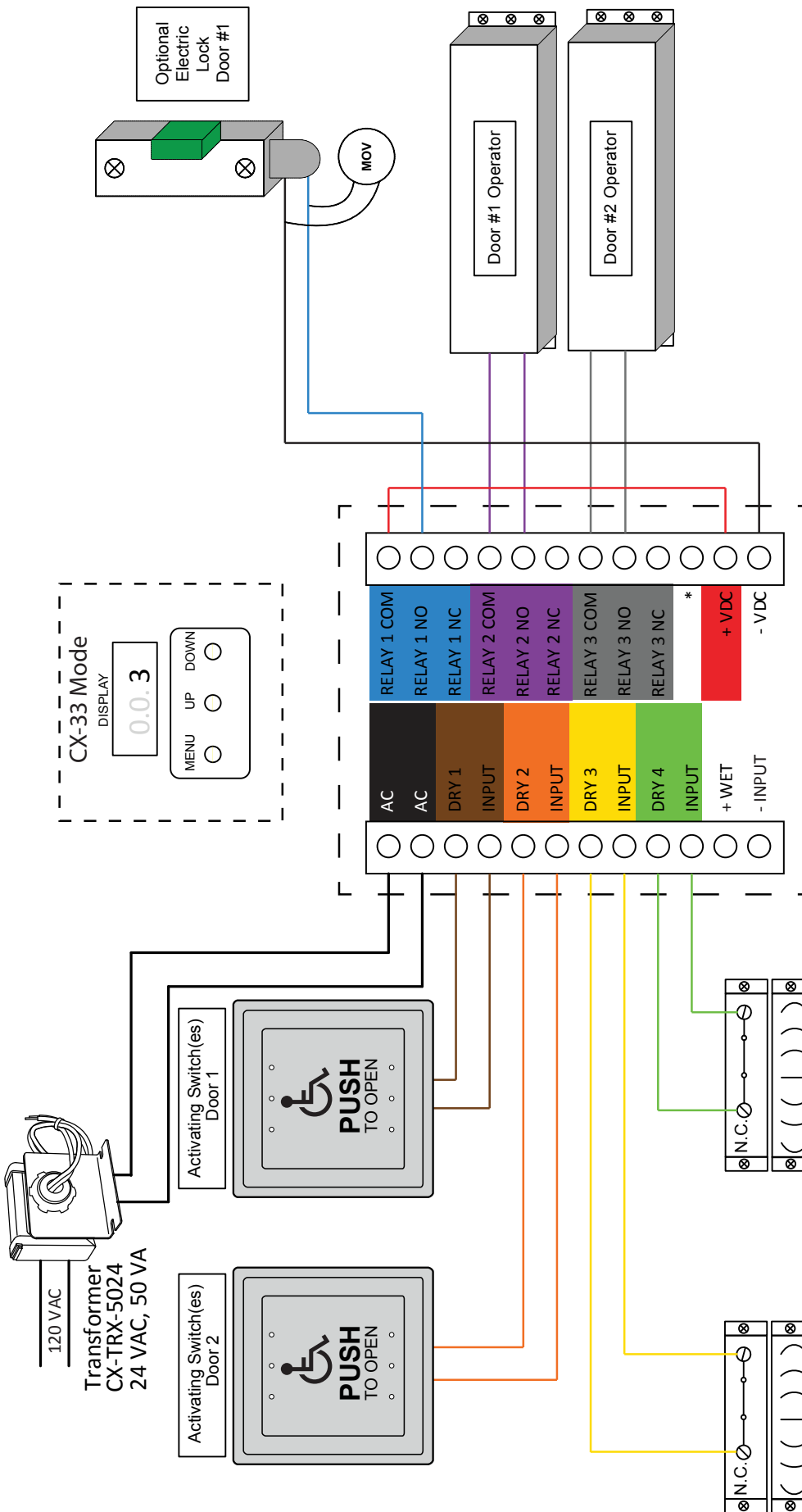

		2395 Skymark Ave, Mississauga, ON L4W 4Y6	
<b>CAMDEN DOOR CONTROLS</b>		DRAWN BY: JML	DATE: 04/17/2020
SCALE: NONE			
REVISED:			
(Mode 3) 2 Door Ratchet Airlock Wiring Diagram			
DRAWING No: DRG-CX-33-PS-03		FILENAME: CX-33PS Diagram 3.ai	

**NOTE:**

- Door Contact circuit must be closed when door is closed, and open when door opens.
- If electric lock is not used, set H1 and D1 timers to 0.D2 is not used in this mode.
- Walk-away feature is used with locks only (not operators). Otherwise, set H2 & H3 Timers to 0.

# CX-33PS Advanced Logic Control Relay & Power Supply Cabinet

## INSTALLATION INSTRUCTIONS

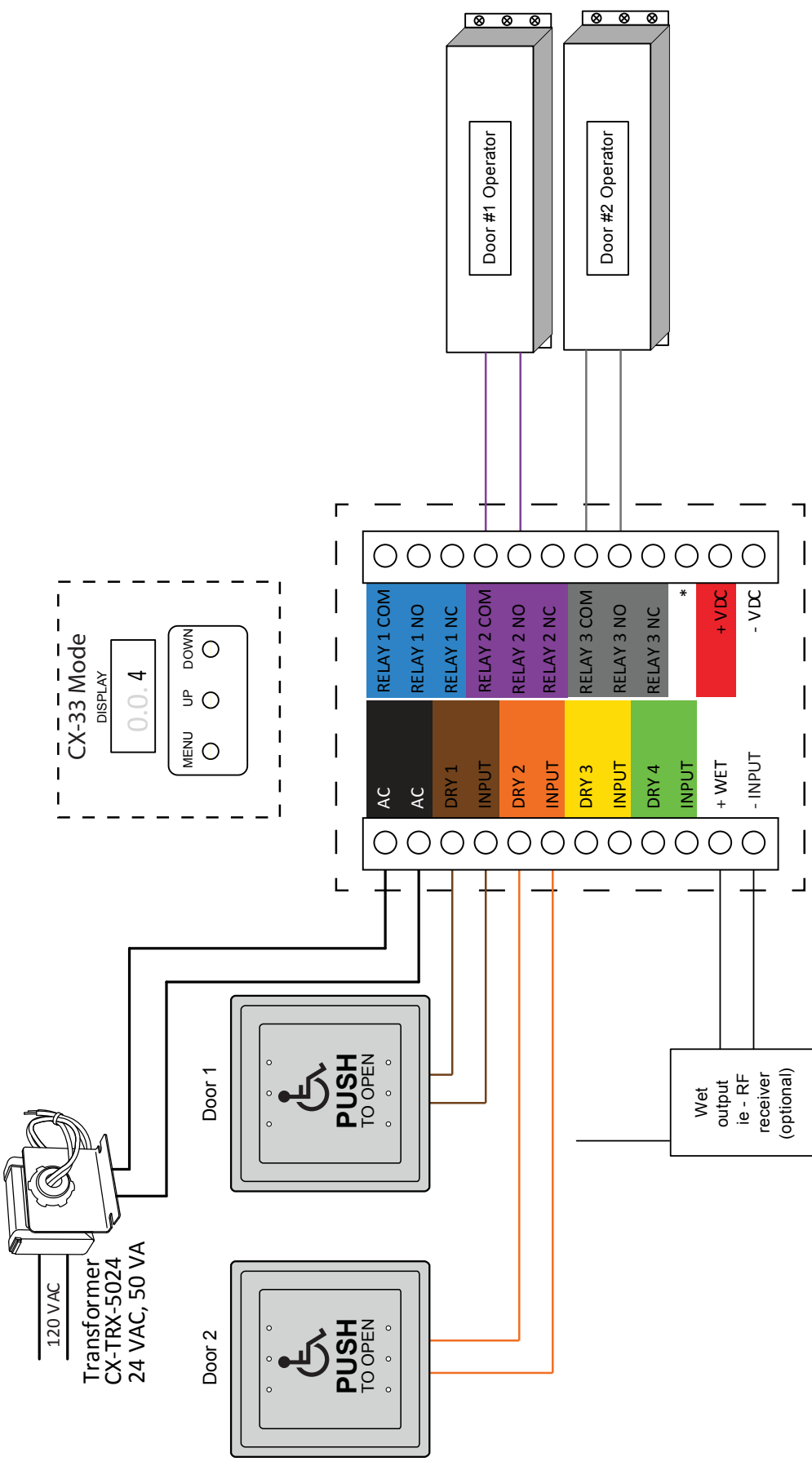

		<b>CAMDEN DOOR CONTROLS</b> 2395 Skymark Ave, Mississauga, ON L4W 4Y6	
SCALE: NONE	DRAWN BY: JML	DATE: 04/17/2020	REVISED:
(Mode 4) Simple Bi-Directional Sequencer Wiring Diagram			
DRAWING No: DRG-CX-33-PS-04a		FILENAME: CX 33PS Diagram 4a.ai	

# CX-33PS Advanced Logic Control Relay & Power Supply Cabinet

## INSTALLATION INSTRUCTIONS

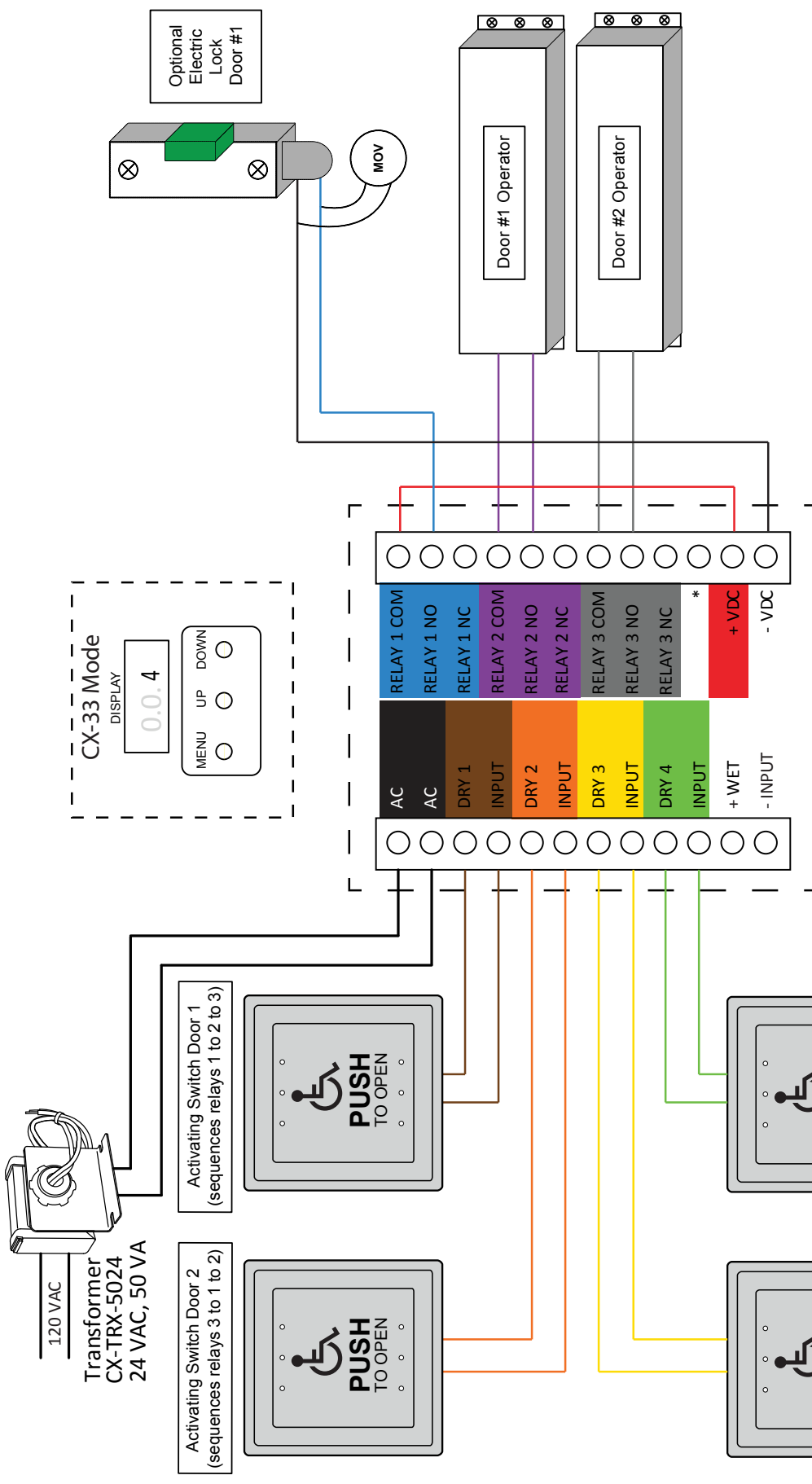

		2395 Skymark Ave, Mississauga, ON L4W 4Y6	
<b>CAMDEN DOOR CONTROLS</b>		<b>CAMDEN DOOR CONTROLS</b>	
SCALE: NONE	DRAWN BY: JML	DATE: 04/17/2020	REVISED:
<b>(Mode 4) 3 Relay Bi-Directional Door Sequencer Wiring Diagram</b>			
DRAWING No: DRG-CX-33-PS-04b		FILENAME: CX 33PS Diagram 4b.ai	

# CX-33PS Advanced Logic Control Relay & Power Supply Cabinet

## INSTALLATION INSTRUCTIONS

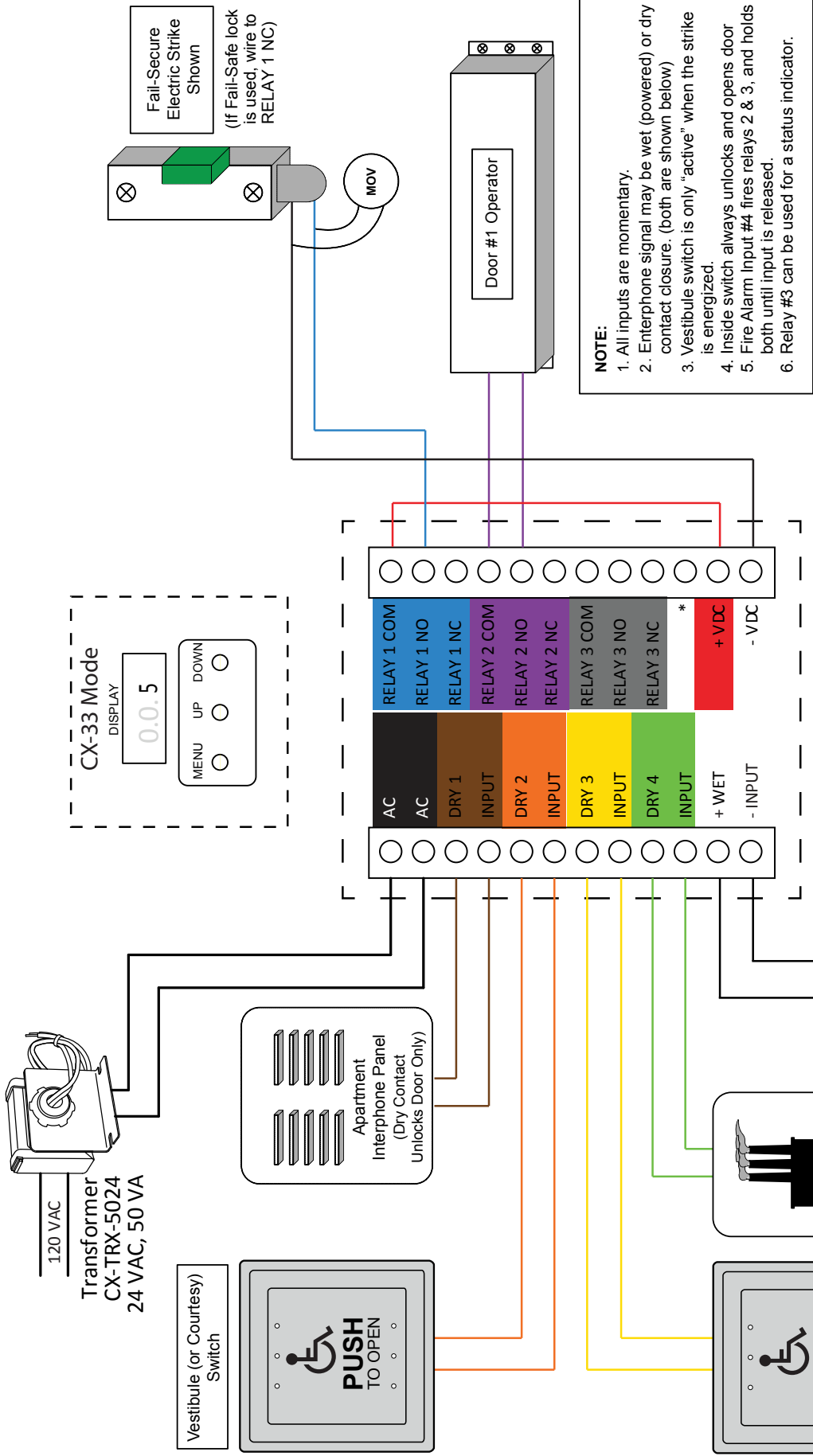

**NOTE:**

1. All inputs are momentary.
2. Enterphone signal may be wet (powered) or dry contact closure. (both are shown below)
3. Vestibule switch is only "active" when the strike is energized.
4. Inside switch always unlocks and opens door
5. Fire Alarm Input #4 fires relays 2 & 3, and holds both until input is released.
6. Relay #3 can be used for a status indicator.

		2395 Skymark Ave, Mississauga, ON L4W 4Y6	
<b>CAMDEN DOOR CONTROLS</b>		DRAWN BY: JML	DATE: 04/17/2020
SCALE: NONE		REVISED:	
<b>(Mode 5) Apartment / Condo Application Wiring Diagram</b>			
DRAWING No: DRG-CX-33-PS-05		FILENAME: CX-33PS Diagram 5.ai	

# CX-33PS Advanced Logic Control Relay & Power Supply Cabinet

## INSTALLATION INSTRUCTIONS

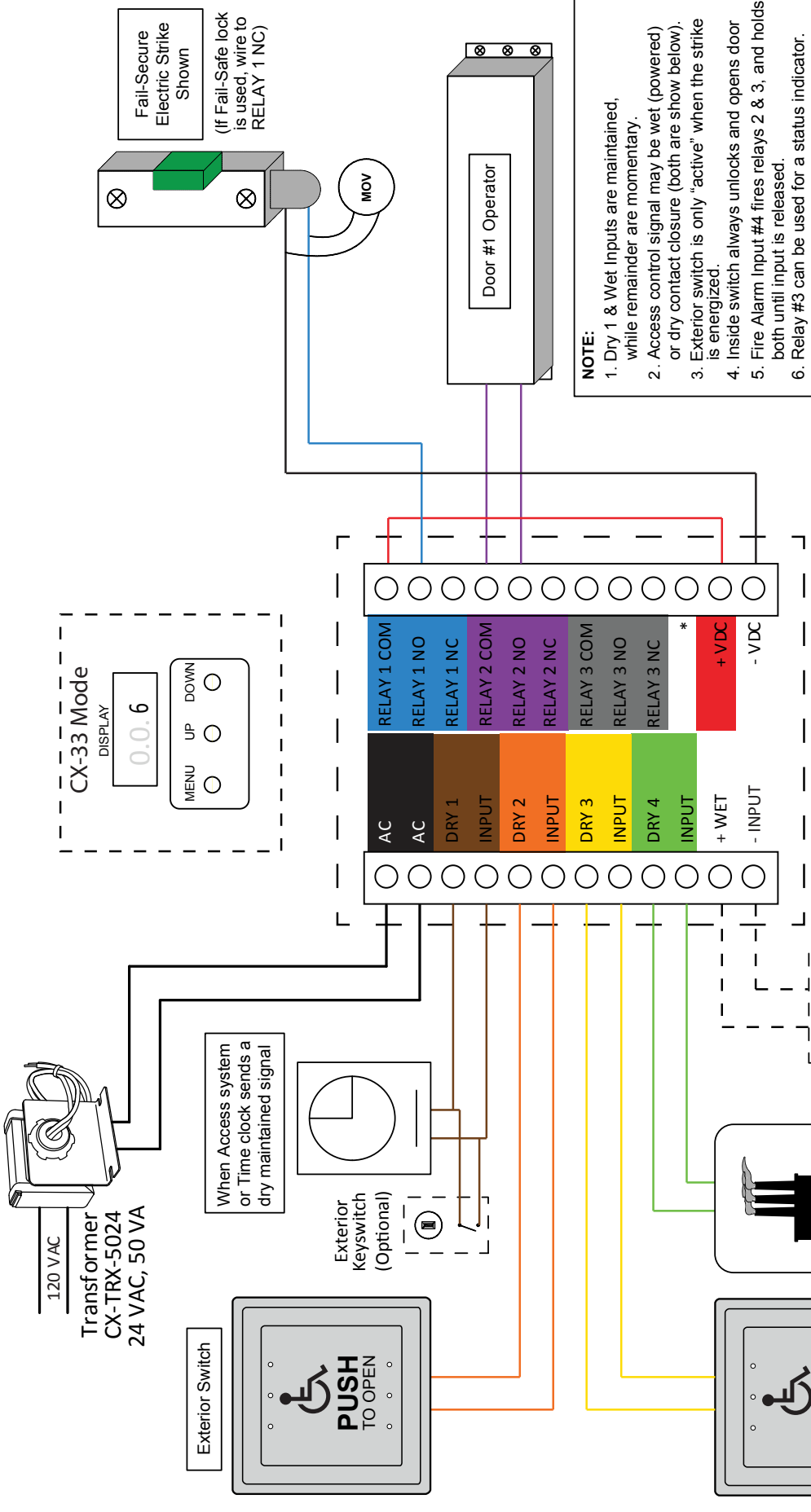

**NOTE:**

1. Dry 1 & Wet Inputs are maintained, while remainder are momentary.
2. Access control signal may be wet (powered) or dry contact closure (both are show below).
3. Exterior switch is only "active" when the strike is energized.
4. Inside switch always unlocks and opens door
5. Fire Alarm Input #4 fires relays 2 & 3, and holds both until input is released.
6. Relay #3 can be used for a status indicator.

		2395 Skymark Ave, Mississauga, ON L4W 4Y6	
<b>CAMDEN DOOR CONTROLS</b>		<b>CAMDEN DOOR CONTROLS</b>	REVISION:
SCALE: NONE	DRAWN BY: JML	DATE: 04/17/2020	REVISED:
(Mode 6) Access Control Application Wiring Diagram			
DRAWING No: DRG-CX-33-PS-06		FILENAME: CX-33PS Diagram 6.ai	

# CX-33PS Advanced Logic Control Relay & Power Supply Cabinet

## INSTALLATION INSTRUCTIONS

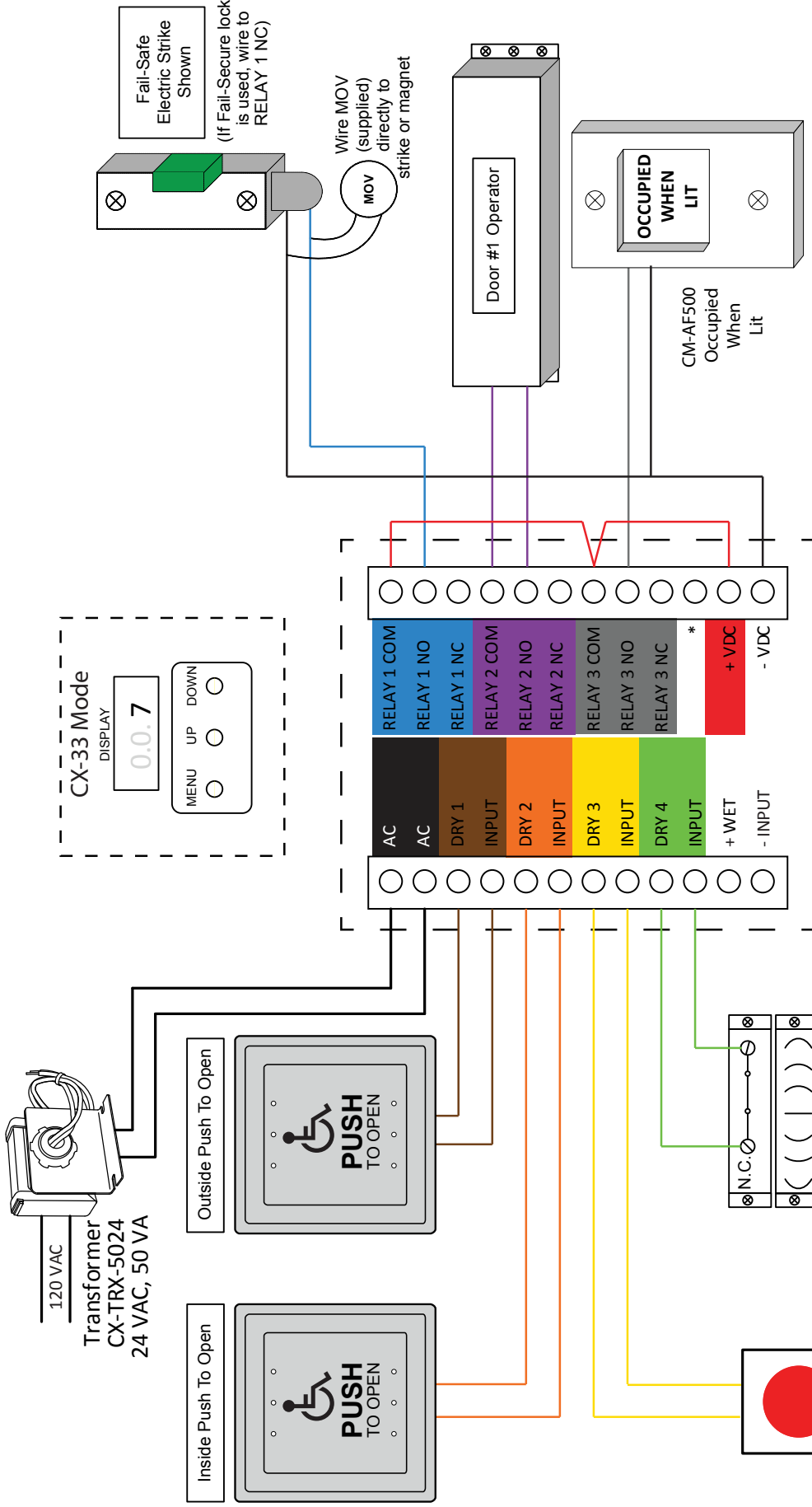

		2395 Skymark Ave, Mississauga, ON L4W 4Y6	
<b>CAMDEN DOOR CONTROLS</b>		<b>CAMDEN DOOR CONTROLS</b>	
SCALE: NONE	DRAWN BY: JML	DATE: 04/17/2020	REVISED:
(Mode 7) Normally Unlocked Washroom Wiring Diagram			
DRAWING No: DRG-CX-33-PS-07		FILENAME: CX-33PS Diagram 7.ai	



# CX-33PS Advanced Logic Control Relay & Power Supply Cabinet

## INSTALLATION INSTRUCTIONS

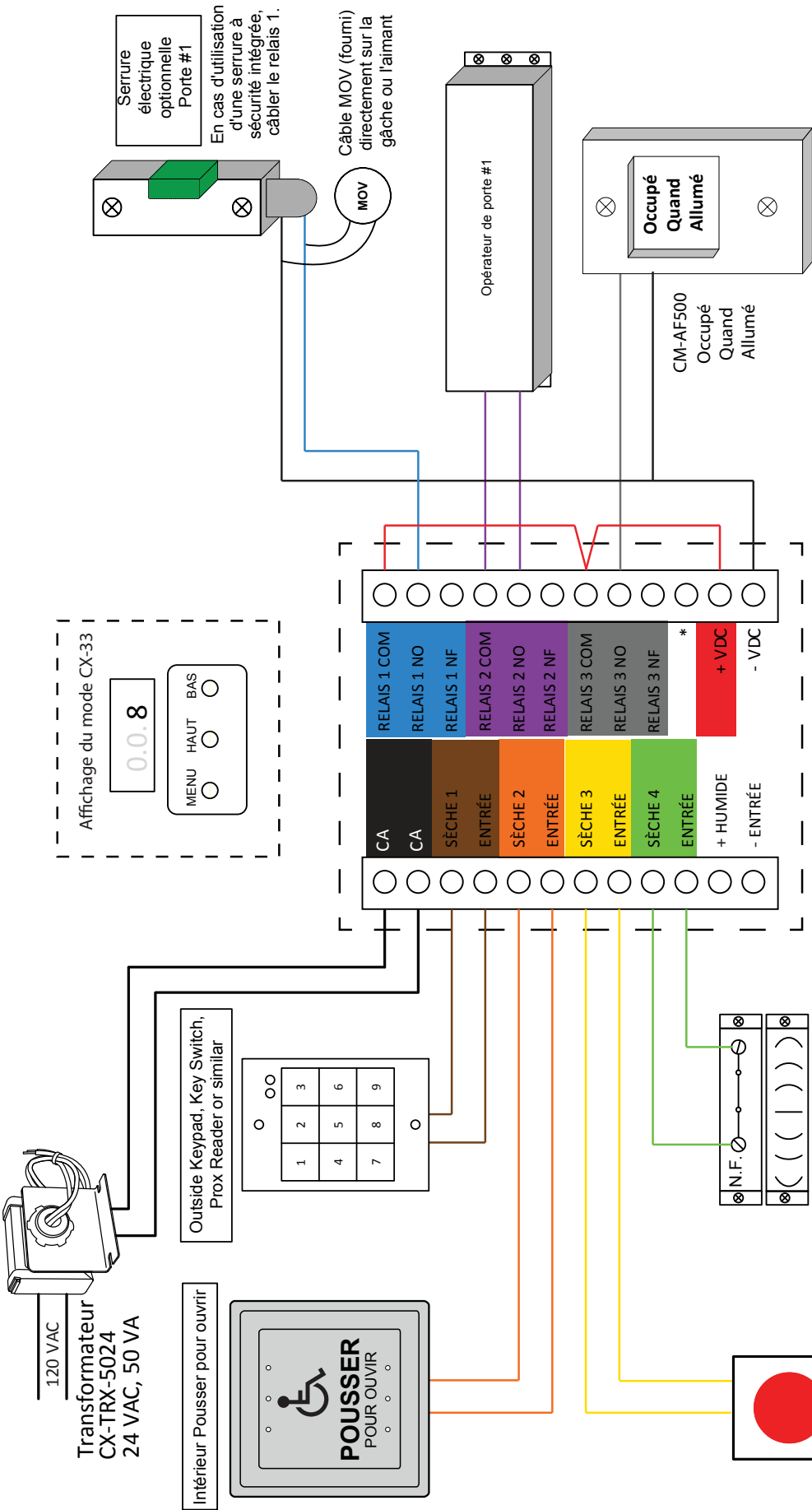

		2395 Skymark Ave, Mississauga, ON L4W 4Y6	
SCALE: NONE	DRAWN BY: JML	DATE: 04/17/2020	REVISED:
<b>CAMDEN DOOR CONTROLS</b> (Mode 8) Normally Locked Washroom Wiring Diagram			
DRAWING No: DRG-CX-33-PS-08	FILENAME: CX-33PS Diagram 8.ai		

# CX-33PS Advanced Logic Control Relay & Power Supply Cabinet

## INSTALLATION INSTRUCTIONS

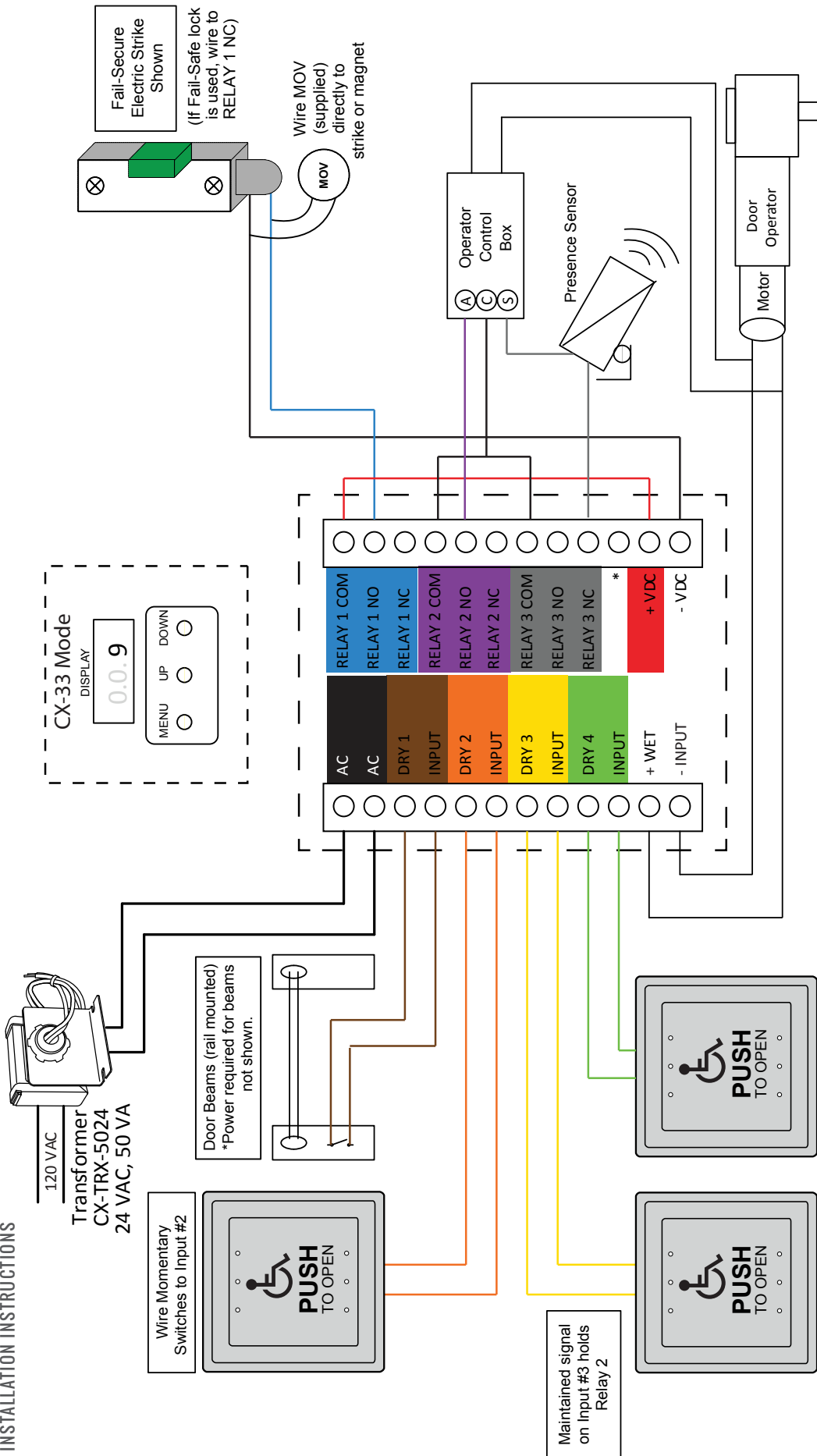

- NOTES:**
- Solid lines are the L.O.R. circuit. Dashed lines are switching network circuit and are optional.
  - Dry inputs 2, 3, & 4 allow for Mixed Mode Triggering. Any or all may be used.
  - The Wet input allows for AC or DC motors up to 120 Volts.
  - Circuit complies with ANSI A156.10 when used with photo eyes as shown.
  - Operator Control box terminals:  
A = Active, C = Common, S = Safety.

Momentary signal on Input #4 latches Relay 2.  
Second signal releases relay.

		2395 Skymark Ave, Mississauga, ON L4W 4Y6	
<b>CAMDEN DOOR CONTROLS</b>		<b>CAMDEN DOOR CONTROLS</b>	
SCALE: NONE	DRAWN BY: JML	DATE: 04/17/2020	REVISED:
(Mode 9) L.O.R. plus Switching Network Wiring Diagram			
DRAWING No: DRG-CX-33-PS-09		FILENAME: CX-33PS Diagram 9.ai	

# CX-33PS Advanced Logic Control Relay & Power Supply Cabinet

## INSTALLATION INSTRUCTIONS

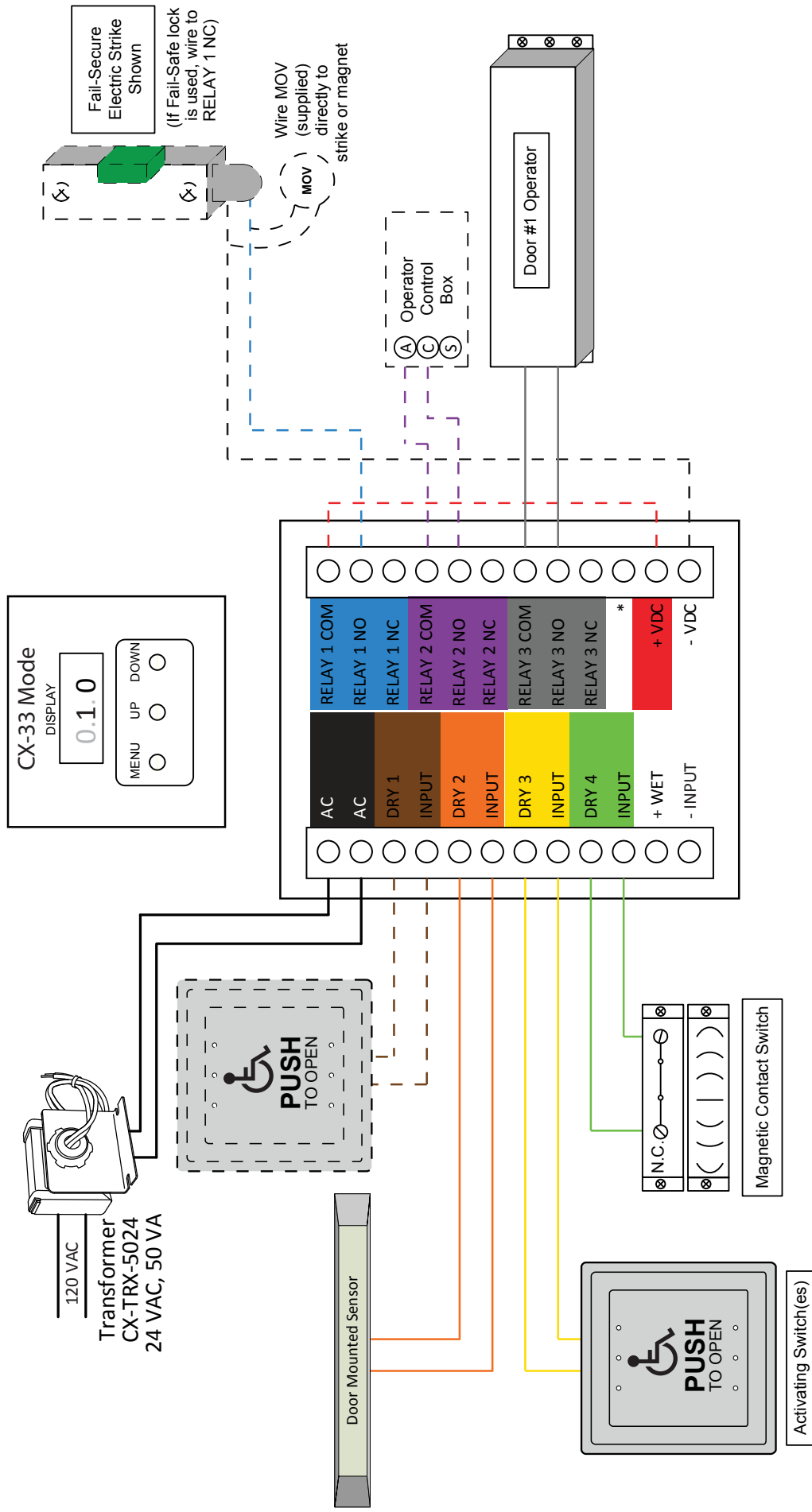

- NOTES:**
- Solid lines are the Secondary Activation Mode (SAM) switching network circuit and are optional.
  - SAM Circuit complies with ANSI A156.19 when wired as shown
  - Sensor is only active after Switch is pressed, and remains active until door closes.
  - The CX-33 also resets after 60 seconds if the door never opens (safety feature) used with photo eyes as shown.
  - Operator Control box terminals: A = Active, C = Common, S = Safety.

		2395 Skymark Ave, Mississauga, ON L4W 4Y6	
<b>CAMDEN DOOR CONTROLS</b>		<b>CAMDEN DOOR CONTROLS</b>	
SCALE: NONE	DRAWN BY: JML	DATE: 04/17/2020	REVISED:
<b>(Mode 10) Low Energy S.A.M. Switching Network Wiring Diagram</b>			
DRAWING No: DRG-CX-33-PS-10		FILENAME: CX-33PS Diagram 10.ai	

# CX-33PS Advanced Logic Control Relay & Power Supply Cabinet

## INSTALLATION INSTRUCTIONS

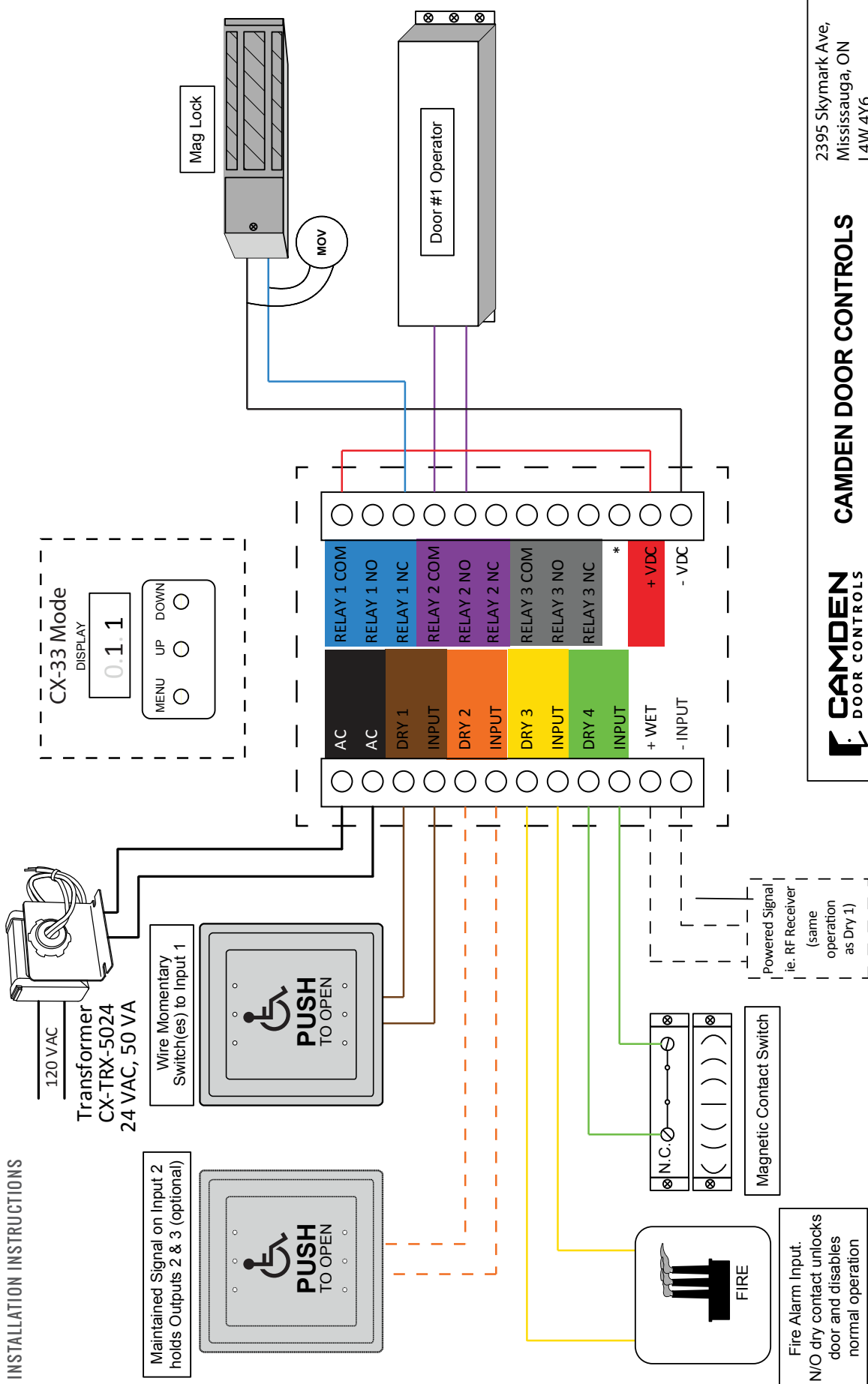

- NOTES:**
1. The magnetic contact Switch circuit must be closed when the door is closed, and open when the door opens.
  2. When the N/O Fire Alarm Circuit closes, the Mag Lock is released, and the wall switch inputs are disabled.
  3. Sensor is only active after Switch is pressed, and remains active until door closes.
  4. All items in dashed lines are optional.

	<b>CAMDEN DOOR CONTROLS</b> 2395 Skymark Ave, Mississauga, ON L4W 4Y6	SCALE: NONE	DRAWN BY: JML	DATE: 04/17/2020	REVISED:
		(Mode 11) Deactivation Timer for Mag Lock Wiring Diagram			
DRAWING No: DRG-CX-33-PS-11			FILENAME: CX-33PS Diagram 11.ai		

# CX-33PS Advanced Logic Control Relay & Power Supply Cabinet

## INSTALLATION INSTRUCTIONS

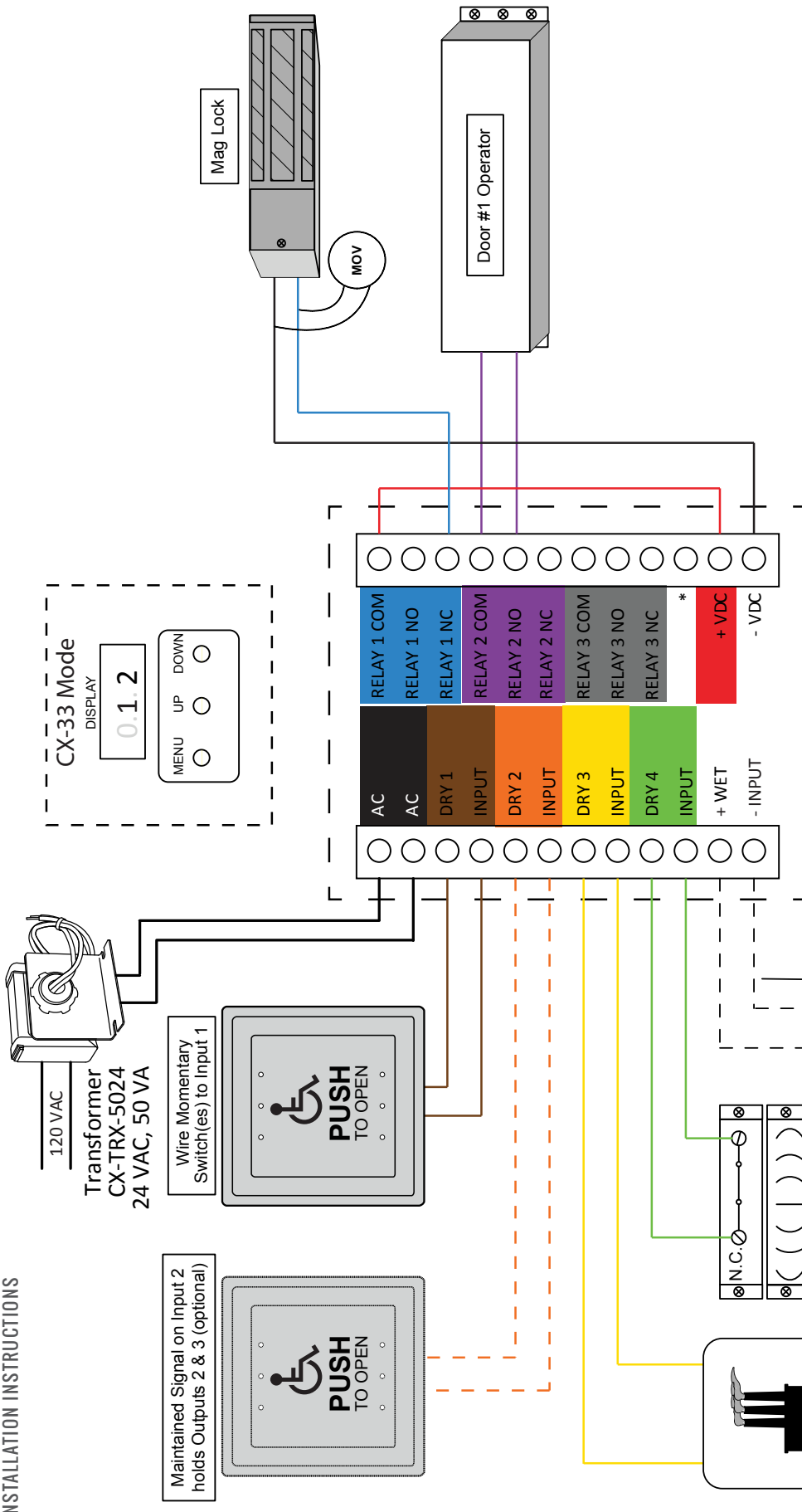

		2395 Skymark Ave, Mississauga, ON L4W 4Y6	
<b>CAMDEN DOOR CONTROLS</b>		DRAWN BY: JML	DATE: 04/17/2020
SCALE: NONE		REVISED:	
<b>(Mode 12) Deactivation Timer for Mag Lock Wiring Diagram</b>			
DRAWING No: DRG-CX-33-PS-12		FILENAME: CX-33PS Diagram 12.ai	

- NOTES:**
1. The magnetic contact Switch circuit must be closed when the door is closed, and open when the door opens.
  2. When the N/O Fire Alarm Circuit closes, the Mag Lock is released, and the wall switch inputs are disabled.
  3. All items in dashed lines are optional.

# CX-33PS Advanced Logic Control Relay & Power Supply Cabinet

INSTALLATION INSTRUCTIONS

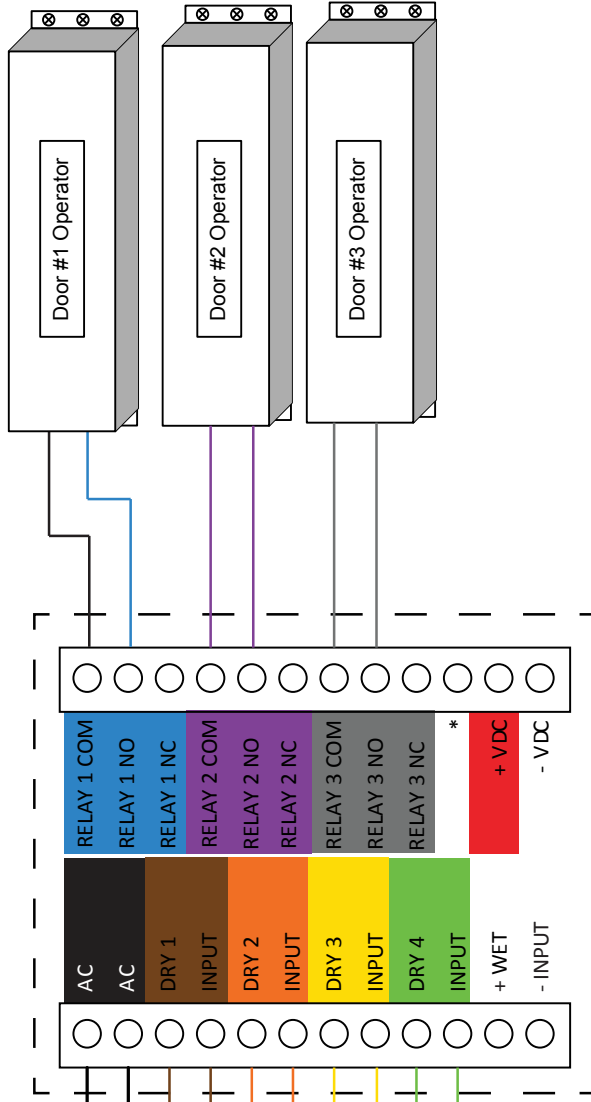
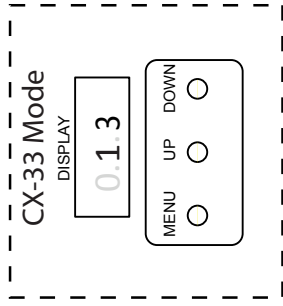
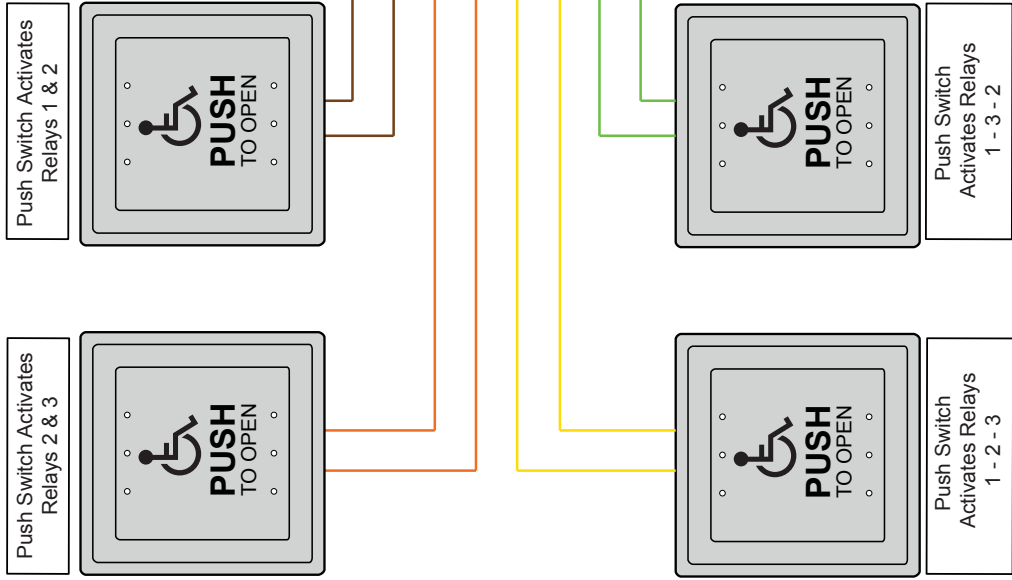
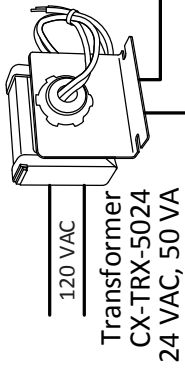

	<b>CAMDEN DOOR CONTROLS</b> 2395 Skymark Ave, Mississauga, ON L4W 4Y6			
	SCALE: NONE	DRAWN BY: JML	DATE: 04/17/2020	REVISED:
(Mode 13) Special Sequencer Wiring Diagram				
DRAWING No: DRG-CX-33-PS-13		FILENAME: CX-33PS Diagram 13.ai		

# CX-33PS Advanced Logic Control Relay & Power Supply Cabinet

## INSTALLATION INSTRUCTIONS

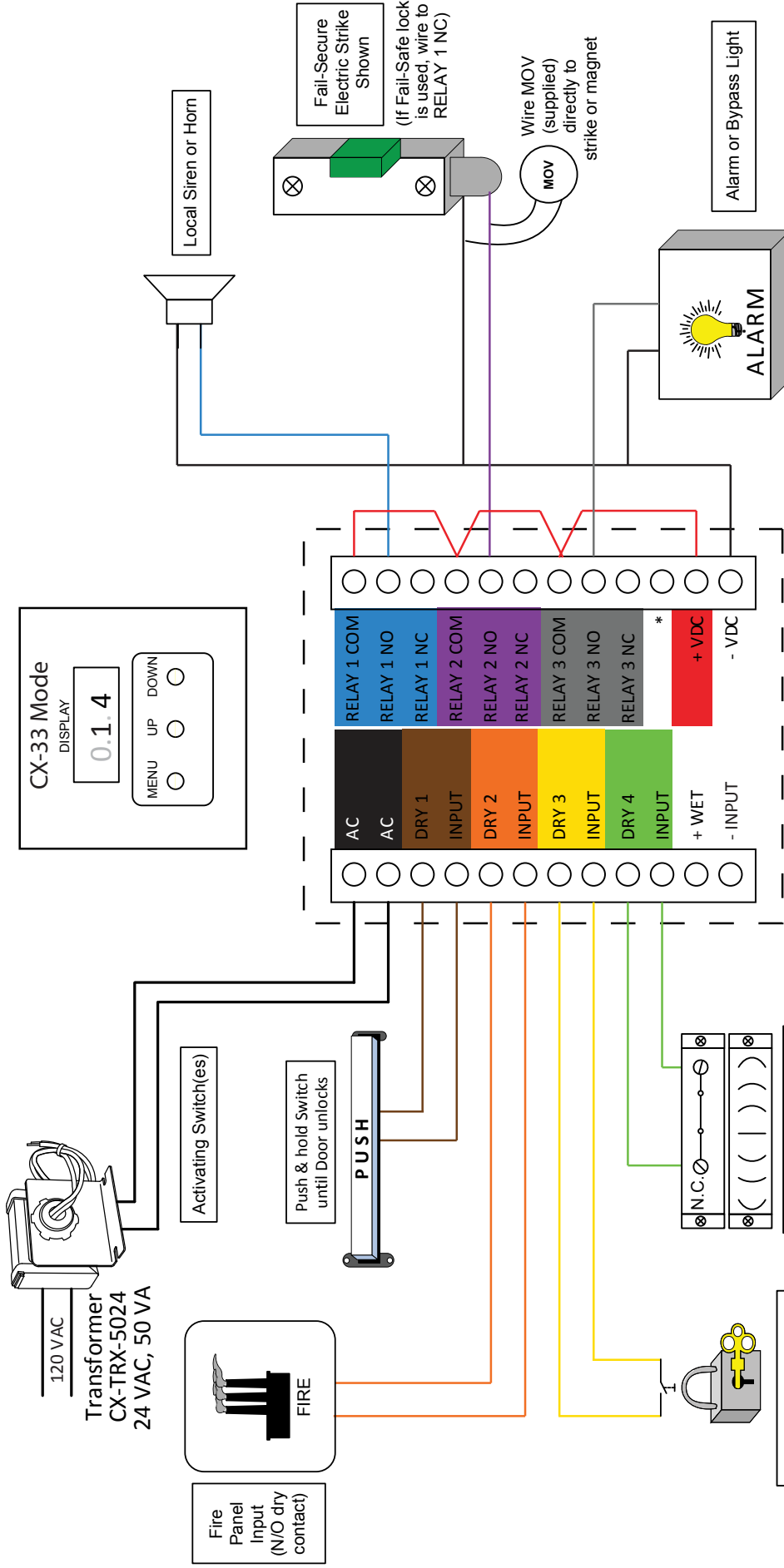

**CAMDEN DOOR CONTROLS**

2395 Skymark Ave,  
Mississauga, ON  
L4W 4Y6

SCALE: NONE

DRAWN BY: JML

DATE: 04/17/2020

REVISED:

### (Mode 14) Deactivation Timer for Mag Lock Wiring Diagram

DRAWING No: DRG-CX-33-PS-14

FILENAME: CX-33PS Diagram 14.ai

#### NOTES:

1. This product does not carry any UL Approval or certification for this mode.
2. Timer (H1) sets the length of time the Push / Panic switch must be pressed & held before the door unlocks.
3. Timer (H2) sets the minimum ON time for the electric lock after release of the Push/Panic Switch.
4. The Bypass or Shunt switch Input and the Fire Panel Input essentially do the same thing – activate relay #s 2 & 3.

# CX-33PS Advanced Logic Control Relay & Power Supply Cabinet

## INSTALLATION INSTRUCTIONS

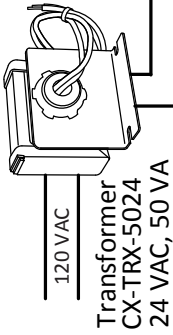

Activating Switch Door 2  
(sequences relays 3 to 1 to 2)

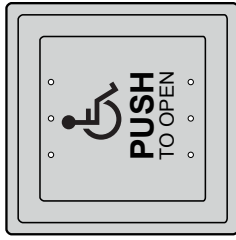

Activating Switch Door 1  
(sequences relays 1 to 2 to 3)

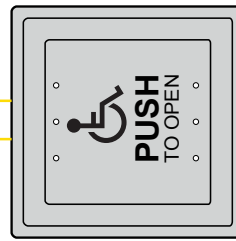
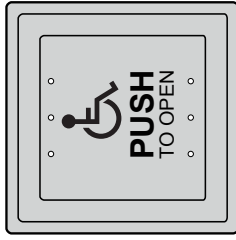

Activating Switch  
(sequences relays 1 & 2 only)

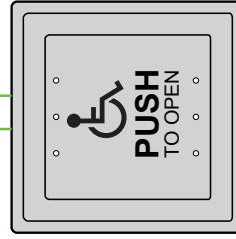

Activating Switch  
(activates relay 3 only)

Optional switches

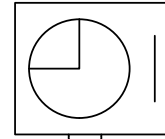

When Access system or Time clock sends a powered & maintained signal.

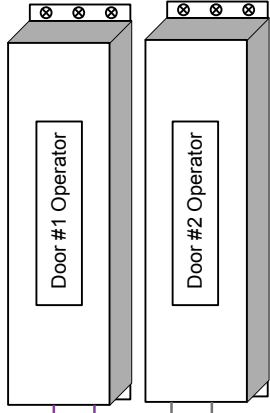
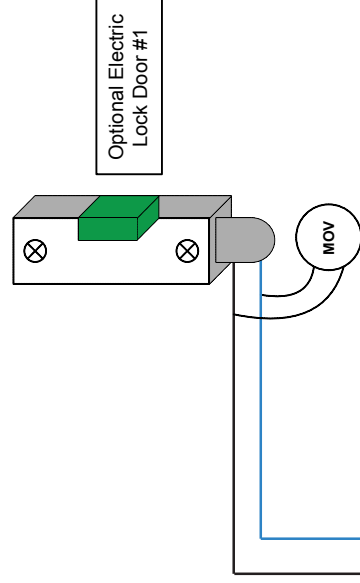
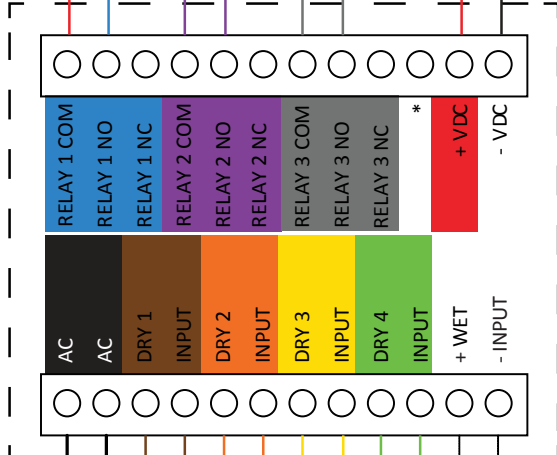
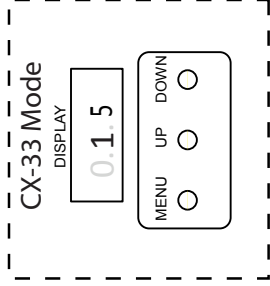

### NOTES:

1. Wet Input is maintained, while remainder are momentary.
2. Access control signal may be wet (powered) or dry contact closure (see DWG# DRG-CX-33-15b)
3. Exterior switch is only "active" when the strike is energized.
4. Inside switch always unlocks and opens door.

	<b>CAMDEN DOOR CONTROLS</b> 2395 Skymark Ave, Mississauga, ON L4W 4Y6			
	SCALE: NONE	DRAWN BY: JML	DATE: 04/17/2020	REVISED:
(Mode 15) 3 Relay Bi-directional Door Sequencer with Access Control Wiring Diagram				
DRAWING No: DRG-CX-33-PS-15		FILENAME: CX-33PS Diagram 15.ai		

# CX-33PS Advanced Logic Control Relay & Power Supply Cabinet

## INSTALLATION INSTRUCTIONS

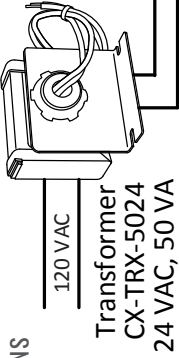

Activating Switch Door 2  
(sequences relays 3 to 1 to 2)

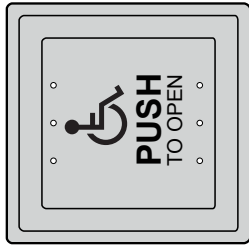

Activating Switch Door 1  
(sequences relays 1 to 2 to 3)

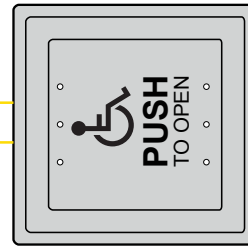
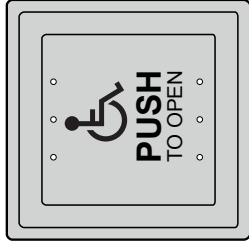

Activating Switch  
(sequences relays 1 & 2 only)

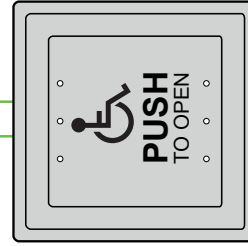

Activating Switch  
(activates relay 3 only)

Optional Switches

When Access system or Time Clock sends a maintained dry signal.

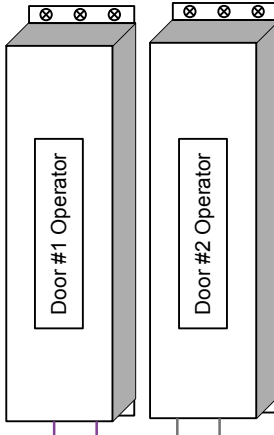
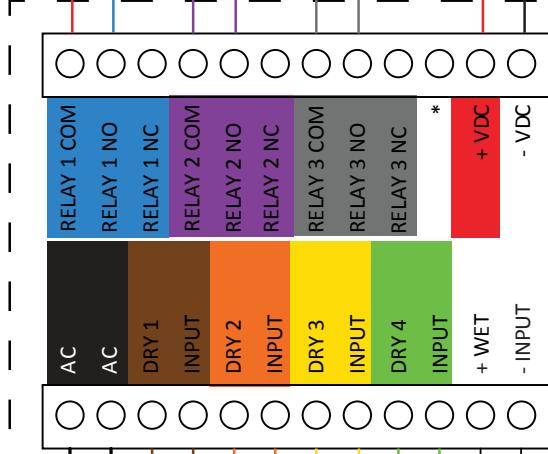
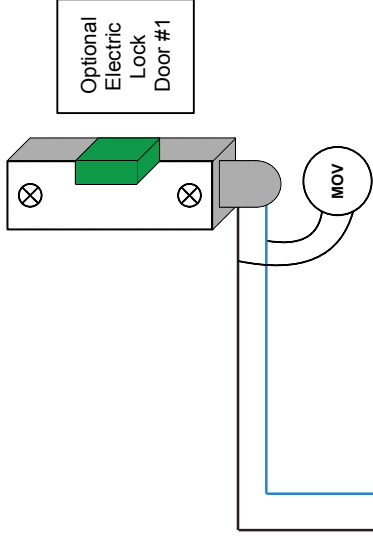
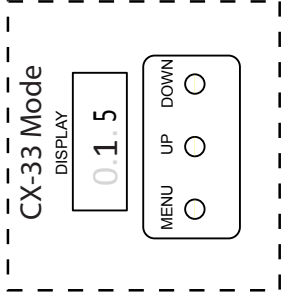

### NOTES:

1. Wet Input is maintained, remainder are momentary.
2. Access control signal may be wet (powered) or dry contact closure (see DWG# DRG-CX-33-15b)
3. Exterior switch is only "active" when strike is energized.
4. Inside switch always unlocks and opens door.



## CAMDEN DOOR CONTROLS

2395 Skymark Ave,  
Mississauga, ON  
L4W 4Y6

SCALE: NONE

DRAWN BY: JML

DATE: 04/17/2020

REVISED:

(Mode 15) 3 Relay Bi-directional Door Sequencer with Access Control Wiring Diagram

DRAWING No: DRG-CX-33-PS-15b

FILENAME: CX-33PS Diagram 15b.ai