

Electrified Locks, Relays and Timers

# CX-ED1799L

## Electric Strike

### INSTALLATION INSTRUCTIONS

#### THIS PACKAGE INCLUDES:

- |                            |                            |                         |
|----------------------------|----------------------------|-------------------------|
| 2 - 4 PIN Power Connectors | 6 - 4-40 x 3/16" Screws    | 2 - 12-24 x 1/2" Screws |
| 10 - B Connectors          | 1 - Door Contact           | 4 - M3 x 5 Screws       |
| 1 - Varistor               | 1 - Two Pin Door Connector | 1 - Dress Plate         |
| 2 - Two Pin Connectors     | 3 - Two Pin Connectors     | 2 - Keeper Shims        |
| 2 - Monitor Switches       | 1 - Dead Bolt Bracket      |                         |



### 1. GENERAL DESCRIPTION

Camden CX-ED1799L Grade 1 electric strike for mortise and cylindrical locksets offer the very best strike quality and features, with the added value of built-in latch monitoring, eight stainless steel faceplates and 'Universal' performance, including field selectable voltage and fail safe/fail secure operation.

### 2. SPECIFICATIONS

Voltage	12/24V AC/DC
Current Draw	300mA@12V AC/DC 150mA@24V AC/DC
Static Strength	1,500 lbs.
Dynamic Strength	70 ft-lbs.
Endurance	1,500,000 Cycles (Factory Tested) 500,000 Cycles (UL Verified)
Mode	Field Selectable Fail Safe/Fail Secure
Operation	AC-Buzz, DC-Silent
Duty	Continuous
Latch Bolt Monitor	SPST, 100mA @ 24V DC
Dead Bolt Monitor	SPST, 100mA @ 24V DC
Strike Monitor	SPDT, 100mA @ 24V DC
Dimensions (Body)	4-7/8" H x 1-5/8"W x 1-21/32" D (124mm x 41mm x 42mm)
Fire Rating	UL 10C/CAN4-S104 3 hrs. (Fail Secure Only)
Approvals	UL Listing #BP10200 for UL 1034 & UL 294 BHMA Certified ANSI A156.31
UL 294 Performance Levels	<ul style="list-style-type: none"> <li>Line Security = Level I</li> <li>Attack Level = Level I</li> <li>Endurance Level = Level IV</li> <li>Standby Power = Level I</li> </ul>

Windstorm Resistant

LATCHING HARDWARE IN ACCORDANCE WITH ANSI/SDI A250.13

TESTING AND RATING OF SEVERE WINDSTORM RESISTANT COMPONENTS FOR SWINGING DOOR ASSEMBLIES

\*ALSO CLASSIFIED IN ACCORDANCE WITH ASTM E330, ASTM E1886, ASTM E1996, TAS 201, TAS 202, and/or TAS 203

### 3. DIMENSIONS

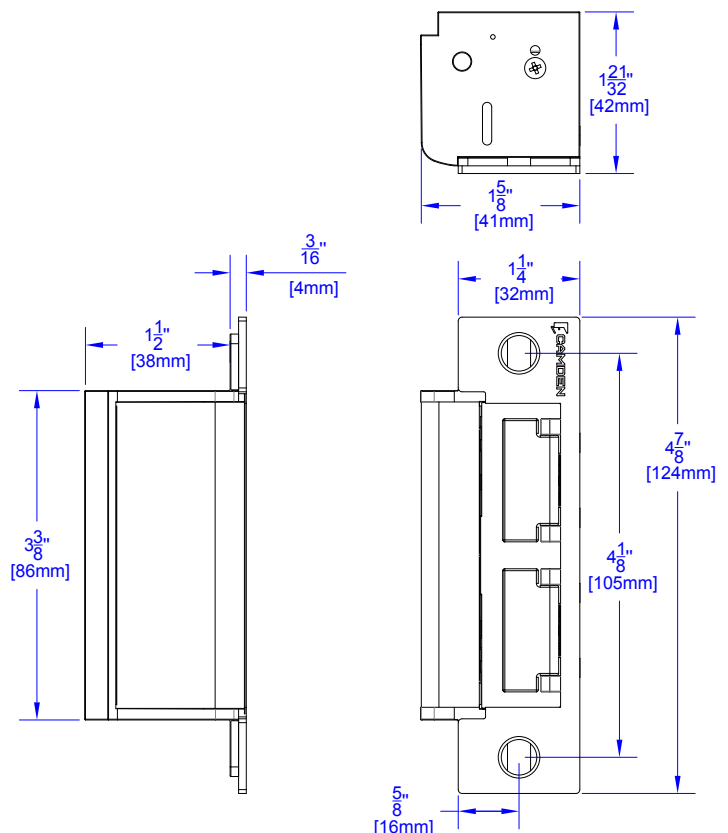

Figure 3.1 Dimensions

**4. INSTALLATION**

**Note:** The products are intended to be installed in accordance with the installation wiring diagram, mechanical assembly drawings provided with each product, the local authority having jurisdiction (AHJ) and the National Electric Code, NFPA 70. When installed in fail secure mode, the local authority shall be consulted with regard to the use of possible panic hardware to allow emergency exit from the secure area.

The electric door strike shall be installed in such a way and in such a location so as to not impair the operation of an emergency exit device or panic hardware mounted on the door.

1. Check that the door jamb has a cutout that fits the strike assembly. If not, refer to figure 4.2 for guidance.
2. Follow the instructions in section 7 to connect the wires.
3. Use the 12-24 x 1/2" machine screws provided to mount the strike onto the door jamb.
4. Test the fit of the electric strike in the mortise. If necessary, adjust it until it fits properly.

**LATCH BOLT INSTALLATION**

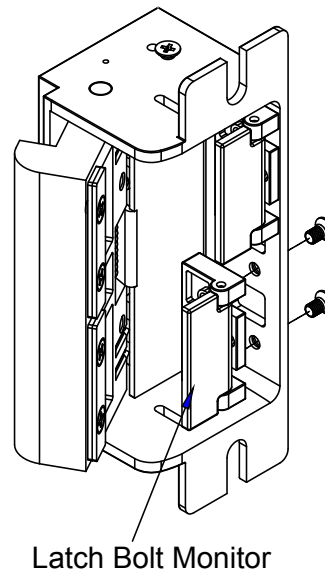

**Note:** Figures show typical installation. The dead bolt bracket, can be mounted in alternate locations depending on RH or LH installation.

Figure 4.1 Latch bolt installation

**ANSI FRAME**

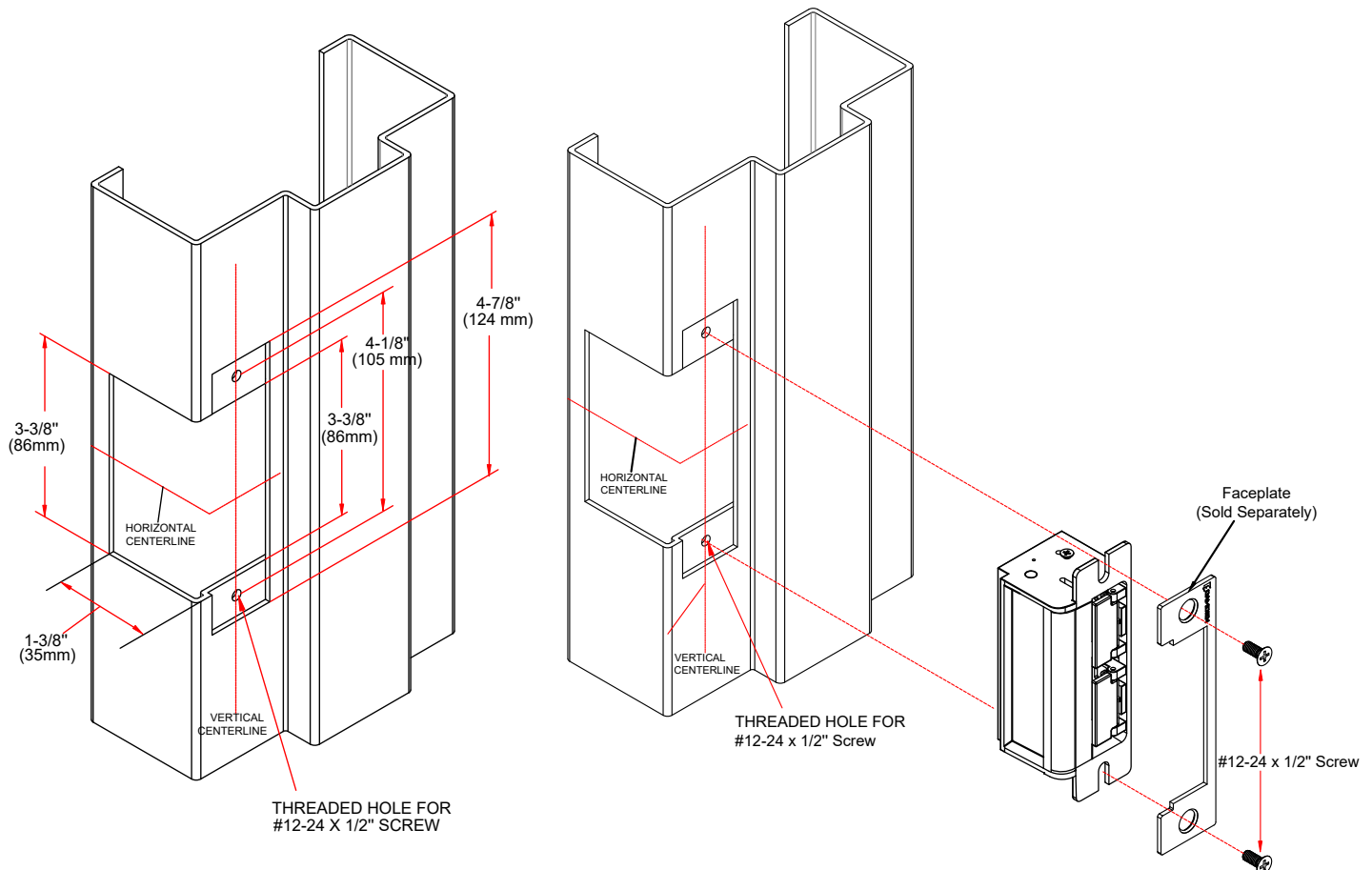

Figure 4.2 Cutout dimensions

## 5. GAP ADJUSTMENT BETWEEN KEEPER AND LATCH

The strike comes with four keeper shims included in the package for adjusting the gap between the keeper and latch. To modify the gap,

1. First loosen and remove the two set screws that secure the keeper shims (see Figure 5.1).
2. Add or remove shims as needed to achieve the desired gap between the latch and keeper.
3. Once the gap is adjusted, securely tighten the two set screws to keep the shims in place.

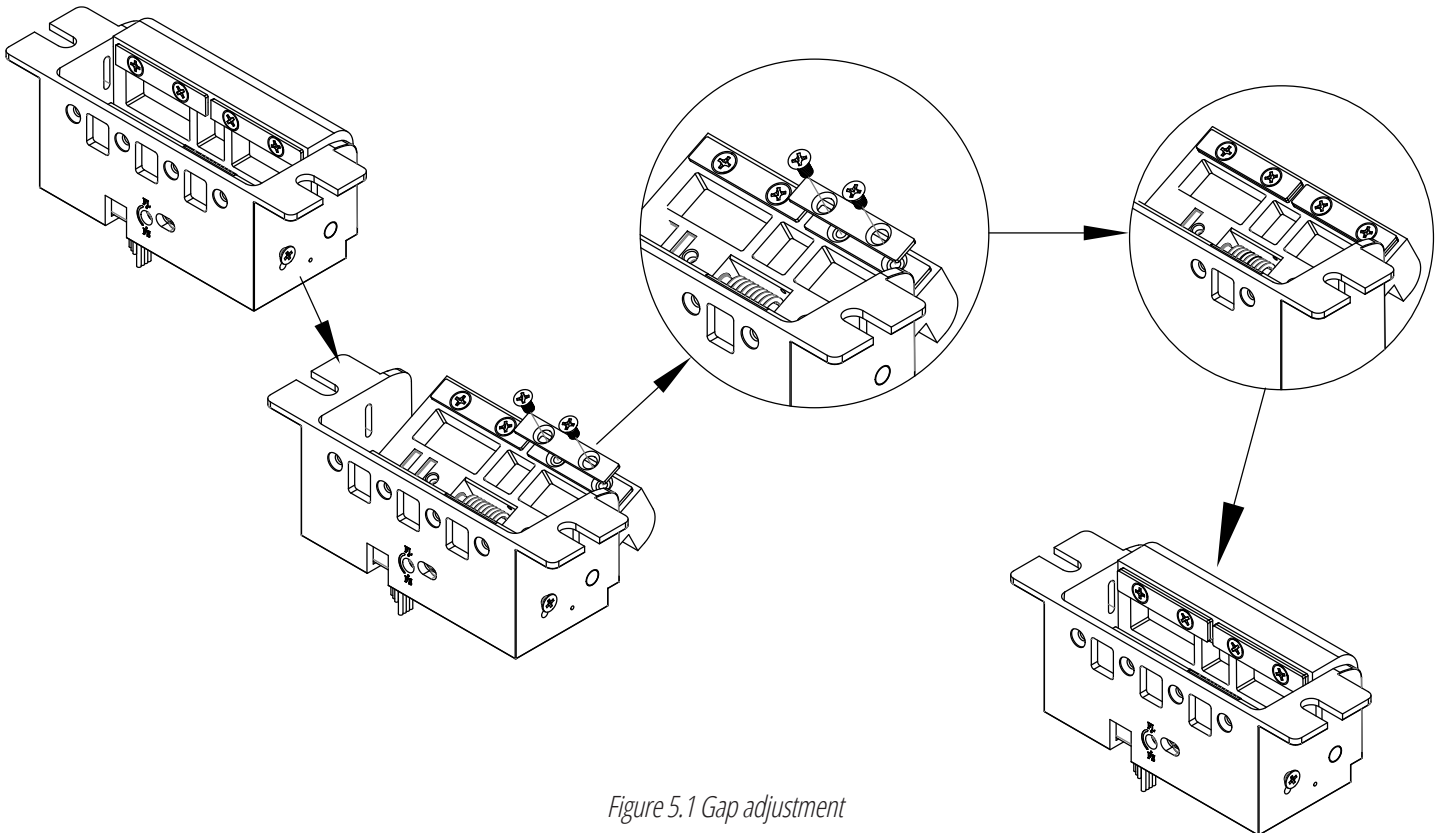

Figure 5.1 Gap adjustment

## 6. DEADBOLT BRACKET INSTALLATION

1. Place the deadbolt bracket inside the strike opening.
2. Align the key on the bracket to fit the key slot on the strike. Ensure the bracket locks to the strike body.
3. With the screw holes aligned, take the supplied # 4-40 x 3/16" Screws, and tighten the bracket in place.

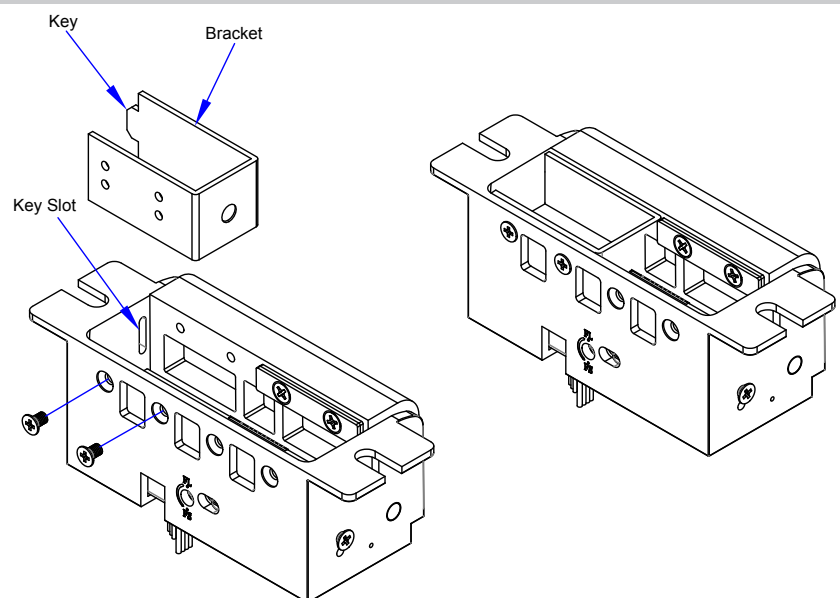

Figure 6.1 Deadbolt bracket installation

## 7. CONNECTION

POWER	
<b>12VDC</b>	<b>24VDC</b>
Red/Black: +12V	Red: +24
Blue/Green: Ground	Green: Ground

A varistor is provided to protect/prevent strike from spikes. Connect varistor between input wires. (See Figure 7.1)

**Note:** For UL 294 / UL 1034 compliance, the door strikes are to be powered via a UL 294/ UL 603 class 2 power limited output from a control panel and or power supply. Furthermore, when powered by AC/DC the units shall use a UL regulated UL 294/ UL 603 power limited class 2 output rated 12/24V with AC on indicator.

### Latch Bolt Monitor

This SPST monitor provides position status for the lockset latch bolt. When the latch is engaged, this monitor will provide a contact closure between the COM (white) and NO (purple) wires.

### Strike Monitor Operation

The Strike Monitor provides status information for the operation of the strike. When the strike is activated this Form C monitor changes state.

### Door Contact

The provided concealed door contact provides the ability to monitor the status of the door in conjunction with the latch bolt monitor. The door contact can be monitored separately or can be connected in series with the latch bolt monitor. The door contact operates with the same logic as the latch bolt monitors. It provides an OPEN connection when the door is open and a CLOSED connection when the door is closed.

## 8. OPERATION

The strike is designed to operate in fail-secure mode by default. However, if needed, it can be changed to fail-safe mode by adjusting the mode screw as follows (See Figure 8.1):

1. Loosen the set screw.
2. Turn the mode screw counterclockwise (CCW) to enable fail-safe mode or clockwise (CW) to enable fail-secure mode.
3. Tighten the set screw.

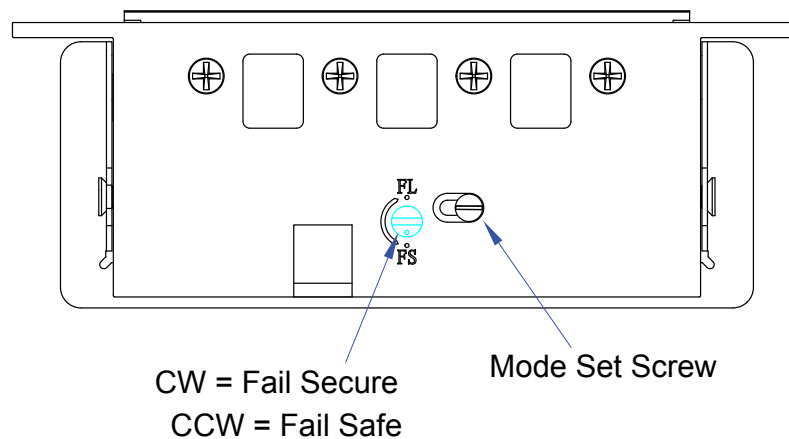
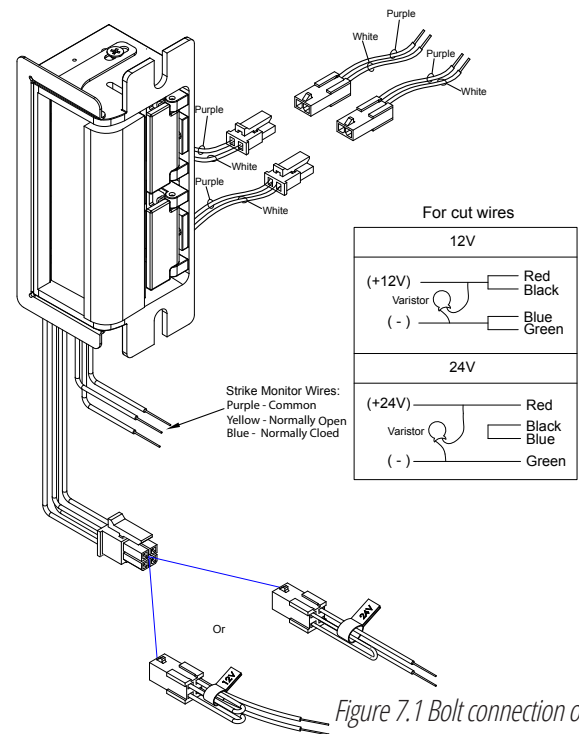
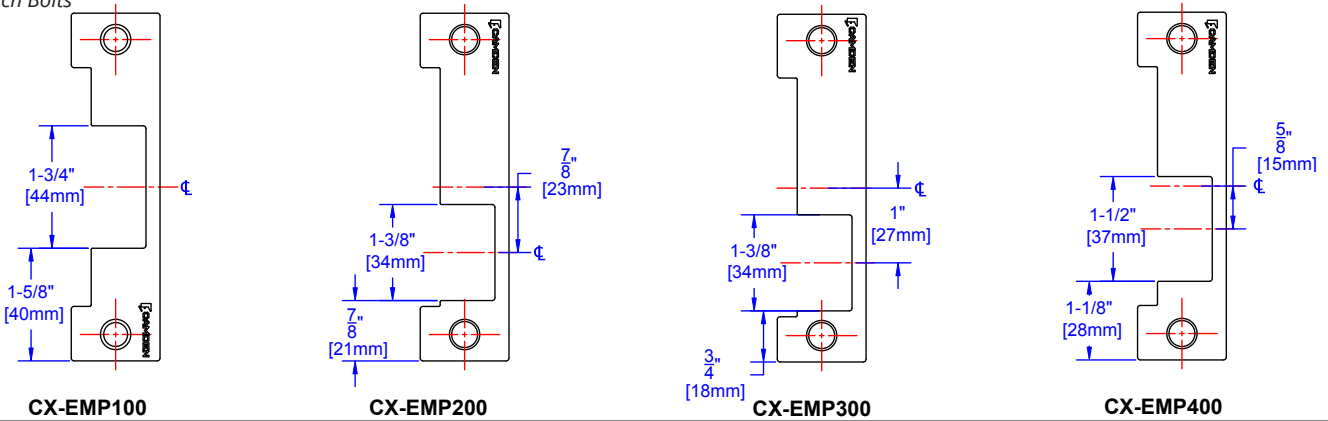

Figure 8.1 Strike operation from Fail Secure to Fail Safe and vice-versa



**9. INCLUDED WITH CX-ED1799L-8**

For Latch Bolts



For Dead Bolts

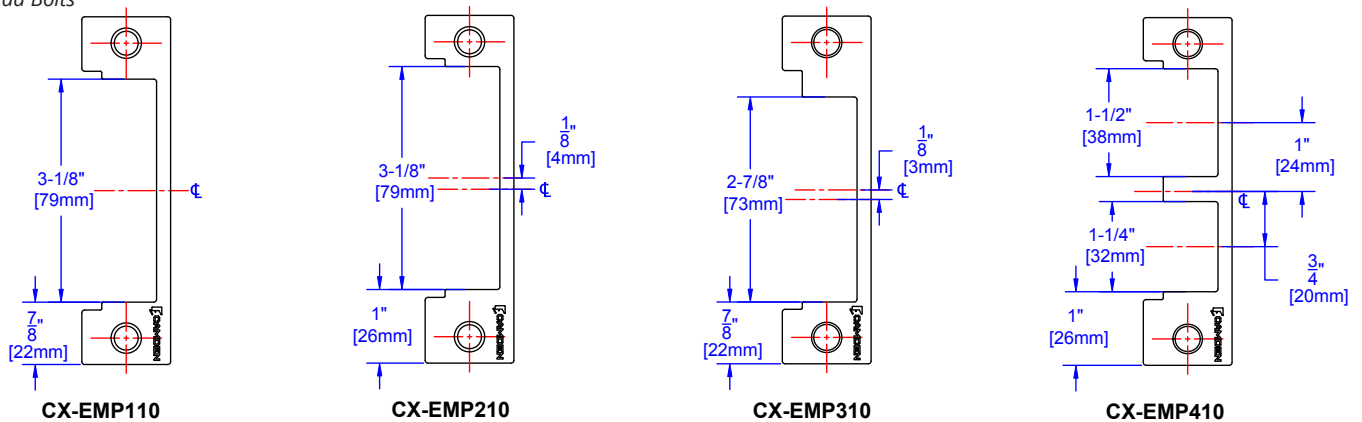

**OPTIONAL**

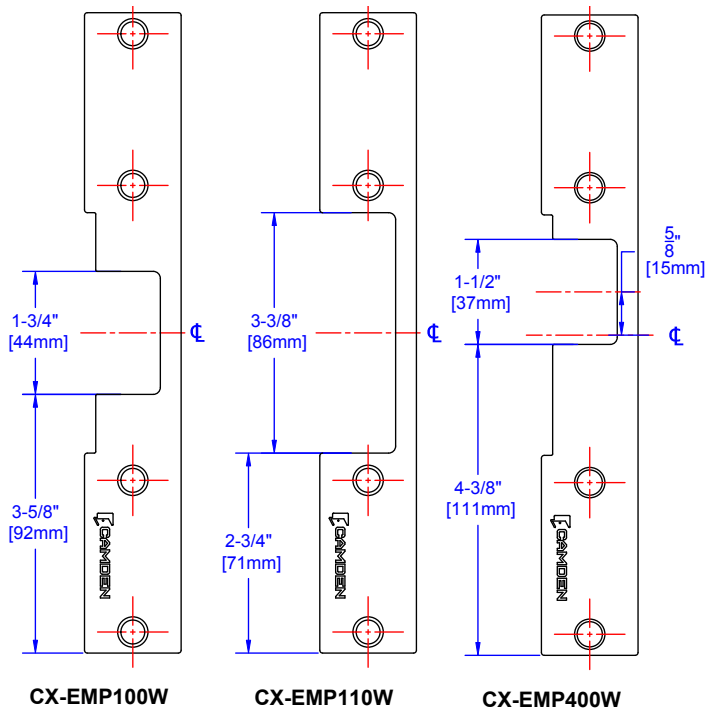

**OPTIONAL FORM C LATCH BOLT MONITOR (60-35E008)**

An optional SPDT Form C Latch Bolt Monitor can be ordered, should you require the output to be different from the standard monitor,

- Figure 9.1 shows optional Form C connection.
- White and Yellow wires can be used for Normally Closed condition while the door is open and Normally Open condition when the door is closed.
- White and Brown wires can be used for Normally Open condition while the door is open and Normally Closed condition while the door is closed.

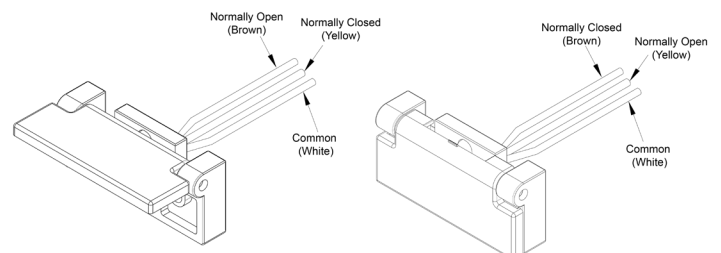

Figure 9.1 Form C Latch bolt connection (optional)