

Electrified Locks, Relays and Timers

# CX-WC17-PS-M1 Series Restroom Kit

## INSTALLATION INSTRUCTIONS

### THIS PACKAGE INCLUDES:

- |                                       |                                |                             |                              |
|---------------------------------------|--------------------------------|-----------------------------|------------------------------|
| <b>Column Switches:</b>               | Screws                         | 1 - Two Pin Door Connector  | 1 - Transformer              |
| 1 - CM-7536/4-LED V2 Column™ Switch   | 6 - Wire Nuts                  | 3 - Two Pin Connectors      | 1 - Surface Mounting Contact |
| 1 - CM-7536/8B-LED V2 Column™ Switch  | 3 - Jumpers                    | 1 - Dead Bolt Bracket       | 1 - 7" x 5" WC Sign          |
| 1 - CM-7536/4 V2 Column™ Switch       | <b>Electric Strike:</b>        | 2 - 12-24 x 1/2" Screws     | 1 - "Occupied When Red" Sign |
| 12 - #14 x 1-1/2" Self Tapping Screws | 1 - CX-ED1799L Electric Strike | 4 - M3 x 5 Screws           | 1 - "Locked When Red" Sign   |
| 12 - Anchors                          | 2 - 4 PIN Power Connector      | 1 - Drhess Plate            | 4 - Foam Tape                |
| 12 - Concrete Anchors                 | 10 - B Connectors              | 2 - Keeper Shims            |                              |
| 12 - 1/4-20 x 1" S/S Pan HD PH        | 1 - Varistor                   | <b>CX-33PS Logic Relay:</b> |                              |
|                                       | 2 - Two Pin Connectors         | 1 - Metal Cabinet           |                              |
|                                       | 2 - Monitor Switches           | 1 - Pre-wired CX-33 Relay   |                              |
|                                       | 6 - 4-40 x 3/16" Screws        | 1 - Power Supply            |                              |
|                                       | 1 - Door Contact               | 1 - Hardware Kit            |                              |



### 1. GENERAL DESCRIPTION

The Camden CX-WC17-PS-M1 Restroom Control Kit allows access in and out of a restroom with the ability to secure the door once inside. The Kit consists of Column™ Switches that provide built-in annunciation with LED illumination.

The CX-WC17-PS-M1 Restroom Control Kit is controlled by Camden's CX-33 advanced relay logic controller (designed to support virtually any automatic door application).

The designation "PS" in the part number reflects that this kit now comes pre-wired in a metal enclosure with a power supply that is ready to accept all field wiring.

#### Operation at a Glance

The CX-WC17-PS-M1 has two modes: **Mode 7** and **Mode 8**.

**Mode 7 "Normally Unlocked" condition:** When the exterior PUSH to OPEN Column™ Switch is pressed, it will send momentary closure to the outside PUSH TO OPEN terminal on the CX-WC17-PS-M1 allowing the door to swing open. When the interior PUSH TO LOCK Column™ Switch is pressed it will send a momentary closure to the to inside PUSH TO LOCK terminal on the CX-WC17-PS-M1 causing it to lock the restroom and turn on the annunciator LED.

When the inside PUSH TO OPEN Column™ Switch is pressed it will send a momentary closure to the inside PUSH TO OPEN terminal on

the CX-WC17-PS-M1 causing it to unlock the door and open it. The annunciator LED will now turn off signalling the restroom is now vacant. The restroom can also be unlocked by opening the door from the inside which will break the door contact circuit causing the CX-WC17-PS-M1 to reset and unlock the door.

**Mode 8 "Normally Locked" condition:** When the exterior PUSH to OPEN Column™ Switch is pressed, it will unlock the strike and trigger the door operator to open the door. Once in the restroom and the PUSH to LOCK Column™ Switch is pressed, it will keep the door locked and disable the exterior PUSH to OPEN Column™ Switch and turning annunciation LED on. When exiting the restroom, you can either press the inside PUSH to OPEN column switch to unlock the door and open the door or you can push the crash bar, paddle or turn the knobset to break the door contact circuit, which will also unlock the door and reset the system. The annunciation LED will turn off, signaling the restroom is available. Note: While exiting, the user can also use the lever handle to open the door; in this case, the system will reset to its initial condition (Mode 7 or Mode 8), and the red light will turn green, allowing other users to use the restroom.

### 2. SPECIFICATIONS

Model	CM-7536/4, 7536/8B-LED V2	Model	CX-ED1799L
Contact Rating	15 Amp @ 30 VDC	Voltage	12/24V AC/DC
Contacts	2 x SPST momentary Contact Switch (Form C), UL Listed	Current Draw	300mA@12V, 150mA@24V DC
LED Current Rating	≤ 20mA @ 12 to 24 VDC	Static Strength	1,500 Lbs.
Construction	Heavy duty extruded aluminum	Dynamic Strength	70 Ft-Lbs.
Finish	Anodized clear, black, blue, dark bronze	Endurance	1,500,000 Cycles (Factory Tested) 500,000 Cycles (UL Verified)
Mounting	4 x #14 wood screws with anchors or 1/4"-20 S/S machine screws	Mode	Field Selectable, Fail Safe/Fail Secure
Actuator Width	3" (76mm)	Operation	AC-Buzz, DC-Silent
Dimensions (overall)	37-1/2" H x 5-7/8" W x 1-1/2" D (955mm x 150mm x 38mm)	Duty	Continuous
Model	CX-33PS Relay Cabinet	Latch Bolt Monitor	SPST, 100mA @ 24V DC
Voltage	AC Input: 12V to 28V; DC Output: 12 or 24V	Dead Bolt Monitor	SPST, 100mA @ 24V DC
Current Supply	2 Amps	Strike Monitor	SPST, 100mA @ 24V DC
Battery Backup	Gel Type (not supplied)	Dimensions (Body)	4-7/8" H x 1-5/8" W x 1-21/32" D (124mm x 41mm x 42mm)
LED Indicator	AC Input and DC Output	Fire Rating	UL 10C/CAN4-S104 3 hrs. (Fail Secure Only)
Temperature	Operating: 0° C to 49° C (32° F to 120° F) Storage: - 20° C to 70° C (- 4° F to 158° F)	Approvals	UL Listing #BP10200 for UL 1034 & UL 294 BHMA Certified ANSI A156.31
Inputs	(4) Dry, (1) Wet 5V to 120V AC/DC, Non-Polarity Optically Isolated	UL 294 Performance Levels	Line Security = Level I • Attack Level = Level I • Endurance Level = Level IV • Standby Power = Level I
Outputs	(3) Form 'C' (SPDT), 3 Amps @ 24V DC	Windstorm Resistant	LATCHING HARDWARE IN ACCORDANCE WITH ANSI/SDI A250.13 TESTING AND RATING OF SEVERE WINDSTORM RESISTANT COMPONENTS FOR SWINGING DOOR ASSEMBLIES *ALSO CLASSIFIED IN ACCORDANCE WITH ASTM E330, ASTM E1886, ASTM E1996, TAS 201, TAS 202, and/or TAS 203
Time Delay	Hold 1 Timer: 0 to 50 seconds Delay 1 Timer: 0 to 15 seconds Hold 2 Timer: 0 to 50 seconds Delay 2 Timer: 0 to 60 seconds Hold 3 Timer: 0 to 50 seconds Delay on Activate: 0 to 10 seconds		
Dimensions	11-1/16" H x 7-7/8" W x 2-13/16" D (281mm x 200mm x 72mm)		

### 3. CX-33PS MOUNTING, WIRING & MODE SELECTION

**IMPORTANT: Do not apply power to the unit until you have fully read the instructions and have made the required adjustments.**

The CX-WC17-PS-M1 Restroom Control Kit includes the CX-33PS Advanced Logic Relay. A complete wiring diagram is included in this manual.

#### Mounting

The CX-WC17-PS-M1 cabinet should be mounted in a clean dry location out of direct contact with the elements.

#### Wiring

The CX-WC17-PS-M1 comes from Camden with the CX-33PS pre-wired to a labeled set of two terminal strips. This will make the

wiring of the push buttons easier since the wiring manual will no longer need to be directly referenced for termination points. A complete wiring diagram is adhered to the inside of the door to provide a layout of the wiring as a reference when wiring the field devices to the kit.

There are two terminal strips that mirror the locations on the CX-33. The left strip is used for power to the CX-33, the PUSH TO OPEN and PUSH TO LOCK column switch, the door position switch, and the Wet trigger. The right strip is for the outputs to drive the strike (Relay 1), door operator (Relay 2), Occupied light (Relay3), and to provide VDC power for the door strike.

Once all field devices are wired to the CX-WC17-PS-M1 then AC power can be wired in.

**IMPORTANT: Confirm the electrical panels breaker you are going to be using is currently off. Do not wire the primary terminals of the transformer until the secondary terminals are connected first.**

The supplied CX-TRX-5024 transformer will have its secondary terminals wired to the terminals on the top of the left terminal strip marked as "AC". Next, wire the primary terminals to the AC feed to be used. Confirm your connections and apply power by turning on the electrical panels breaker.

**Mode Selection**

Mode selection depends on the user requirements;

- If the user wants the restroom unlocked during the idle state, use Mode 7.
- If the user wants the restroom locked during the idle state, use Mode 8. Additional contact block for Mode 8 - Fail Secure is not included; order Part Number 60-66C000.

Figure 3.1 Adjusting the Settings in CX-33

Display ( M )	Description ( Mode you are in )	Parameters ( 1-15 )
H, then 1	Relay 1 Hold Time	0.0 to 50 seconds
d, then 1	Relay 2 Delay Time	0.0 to 15 seconds
H, then 2	Relay 2 Hold Time	0.0 to 50 seconds
d, then 2	Relay 3 Delay Time	Depends on Mode
H, then 3	Relay 3 Hold Time	0.0 to 50 seconds
d	Sets the display ON or OFF during operating mode	ON or OFF
A	Input delay on Activate. If other than 0.0 is selected, the input must be held in for the time period chosen before the CX-33 will activate.	0.0 to 10 seconds
1	Set Dry Input 1 to activate on normally open or normally closed contact.	N/O OR N/C
2	Set Dry Input 2 to activate on normally open or normally closed contact.	N/O OR N/C
3	Set Dry Input 3 to activate on normally open or normally closed contact.	N/O OR N/C
4	Set Dry Input 4 to activate on normally open or normally closed contact.	N/O OR N/C
5	Set Wet Input 5 to activate when voltage applied or removed.	N/O: voltage applied to activate; N/C: voltage removed to activate.

**Note:** The default mode for the CX-WC17-PS-M1 is Mode 7 (normally unlocked).

There are three LED displays that will allow you to see what mode you have selected when advancing through the modes. To change the mode of the CX-WC17-PS-M1, simply press the MENU button once and use the UP button to advance to the desired mode.

**Mode Editing**

Camden builds in typical times for lock release and door operator activation, and is ready to use without changing any parameters. If you need to change the timing or delay for an output, it can be done by pressing the MENU button within the mode you selected. Once the option is selected, you can use the UP or DOWN buttons to select the timing needed. The first option (H & 1 flashing) will be how long relay 1 will be activated for (0-50 seconds). The second option (d & 1 flashing) will be how long to wait before activating relay 2 (0-15 seconds). The third option (H & 2 flashing) will be how long relay 2 will be activated for (0-50 seconds). The fourth option (d & 2 flashing) will be how long to wait before activating relay 3 (0-15 seconds). The fifth option (H & 3 flashing) will be how long relay 3 will be activated for (0-50 seconds). See the Table 3.1

**Factory Reset (Defaulting the CX-33)**

To return the CX-33 back to its factory default settings, you must remove the power, then hold down the MENU button while powering up the CX-33. Once started, you will see the firmware version listed, and number "1" will be displayed. Reconnect your power and press the MENU button once, then use the UP or DOWN button to advance to the desired mode. For proper functionality, fully test the operation of the CX-WC17-PS-M1.

**4. CM-7536-LED V2 COLUMN SWITCH INSTALLATION**

Code Requirements: If installed according to these instructions the CM-7536-LED V2 Column™ Switch will meet the requirements of the California Building Code (Section 1117B.6, Date: 2009), and Section 3.8.3.3.17(b) of the Ontario Building Code.

CM-7536-LED V2 complies with the National Building Code of Canada reference to CSA Regulation 5.2.9.3 (c) ii.

The CM-7536-LED V2 Hands-Free Column™ Switch is a VDC device only and will accept a range of VDC power from 12VDC to 24VDC (+/- 10%. Do not connect AC voltage to the CM-7536-LED V2 at any time.

**Installation Steps:**

1. Unpack the pre-assembled unit from the box. To mount the switch, it is required to disassemble a few components. Firstly, remove two Phillips screw holding the top End Cap in place. Once both screws are removed, take out the cap. (Figure 4.1)
2. Carefully pull out the actuator and place it aside so as to protect it from any surface damage. (See Figure 4.1, 4.2 and 4.3 for reference.)
3. Determine and mark the optimum height and mounting location from the finished floor to mount the Column™ Switch.

We recommend drilling a 3/4" Ø hole along the Guide Channels at the upper end of the Base between 8" and 12" from the top of the Column™ Switch. You may drill a different size that matches your in-wall wiring, this hole location must align with the wires from the wall or in-wall electrical box.

4. Center the switch over the box for wire connection, while lining up the top edge with your mark (If installing through an in-wall electrical box), drill a Ø 1/4" (6.4mm) hole for wire connection (If installing without an in-wall electrical box).
5. Using a level tool, ensure the base unit is perfectly leveled and mark 4 mounting locations through the adjustable nylon inset screws onto the wall surface (if mounting on drywall, use a pencil, and if mounting on concrete wall, use a narrow sharp object for marking).
6. a. Drill the wall at the four marked locations and insert the appropriate wall or concrete anchors provided for the #14 screws.  
b. **If mounting the Column™ Switch on an aluminium post or framing section**, drill and tap four holes for 1/4"-20 stainless steel machine screws (also provided). Note: Camden CM-75SB Series Surface Box is available to mount a Column™ Switch.
7. a. **If hardwiring:**

Use the supplied wire nuts to connect wires. Push excess wires in the back and ensure cables are not exposed to the moving parts of the Switch, or pinched between the back of the base unit and wall surface.

Four nylon inset screws may be turned in or out to help plump up and adjust the Column™ Switch for wall irregularities. Check with a level. When satisfied, install and tighten the four mounting screws.

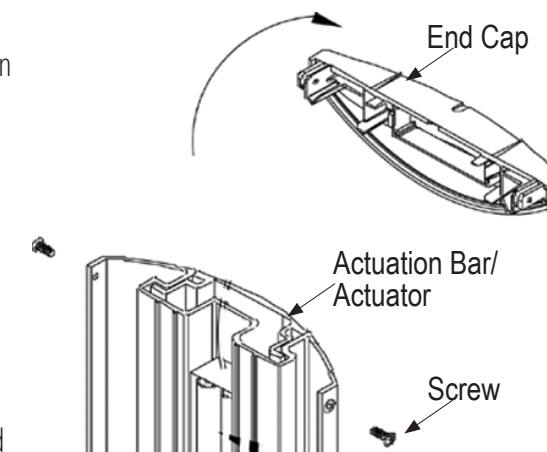

Figure 4.1 End Cap Removal

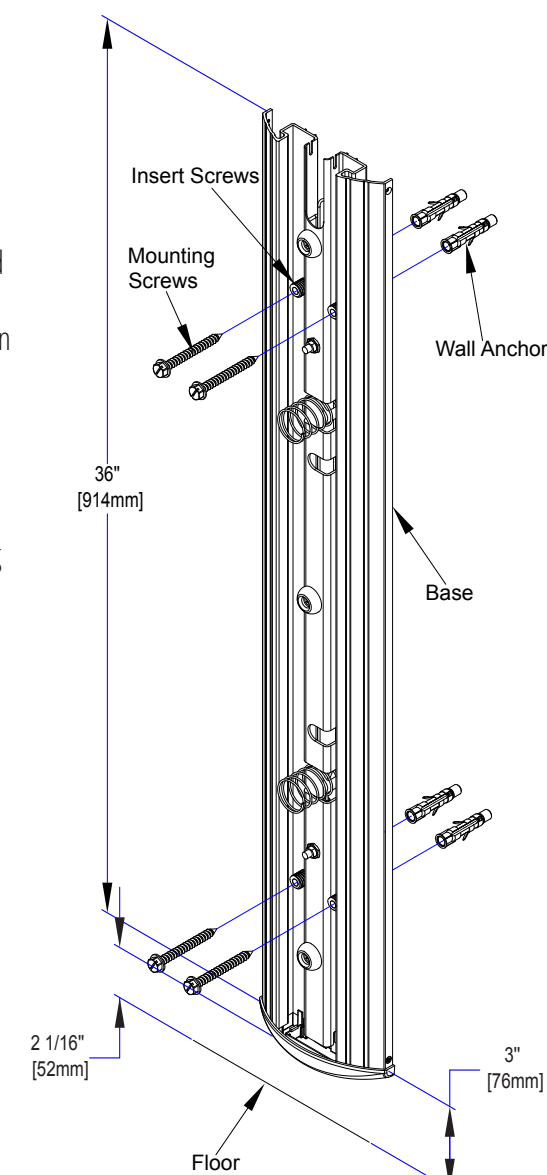

Figure 4.2 Mounting of Base Unit

**b. If using Lazerpoint RF:**

The cap includes a snap-in compartment for our TX-9 transmitter. Place transmitter in the cap, with the wires hanging down and to the front of the cap. Using the supplied wirenuts, connect the two activating wires to the Column™ Switch lead wires. Slide the battery and the extra wiring into the center (rear) channel provided. Do not slide all of the wire into the channel, so that the cap can hang off to one side while you perform the next step. (Figure 4.4)

Using the supplied wire nuts, connect the two activating wires to the Column™ Switch lead wires. Then, slide the battery and the extra wiring into the center (rear) channel provided. Do not slide all of the wire into the channel, so that the cap can hang off to one side while you perform the next step.

**c. If using Kinetic RF:** The CM-7536K uses 2 Kinetic RF switches installed near the top and the bottom of the actuator. When pairing this switch with a Kinetic receiver, you must pair both the top and the bottom switches. The pairing of Camden Kinetic transmitters is detailed in the CM-RX90v2 installation manual. (Figure 4.5)

**d. If using other RF:** Using the supplied wire nuts, make your wire connections to the RF transmitter and tuck the transmitter

and excess wire into the back box (or wall cavity). Ensure cable is not exposed to the moving parts of the switch, or pinched between the back of the base unit and the surface of the wall.

- Reassemble the (center) actuation bar into base unit. This is done by holding the hanger (located at the top center) vertically 'up' – then carefully sliding actuation bar down the length of the base unit, being careful not to bend or break the springs or internal switches.

When the bottom edge of the actuation bar reaches the height of the springs, use your free hand to tuck in the spring and switches under the actuation bar as it slides over them. When activation bar is approx 2" from bottom, position hanger so it falls into the slots provided at the top of the base unit. Slide actuation bar down until it rests on the hanger. Actuation bar should now move freely within the base unit. Test the operation of the switch before mounting the cap.

**Note:** Make sure the hanger sits perfectly into the slot while placing the actuation bar back.

- When satisfied with the switch operation, place the End Cap back to top and secure with the two self-tapping screws.

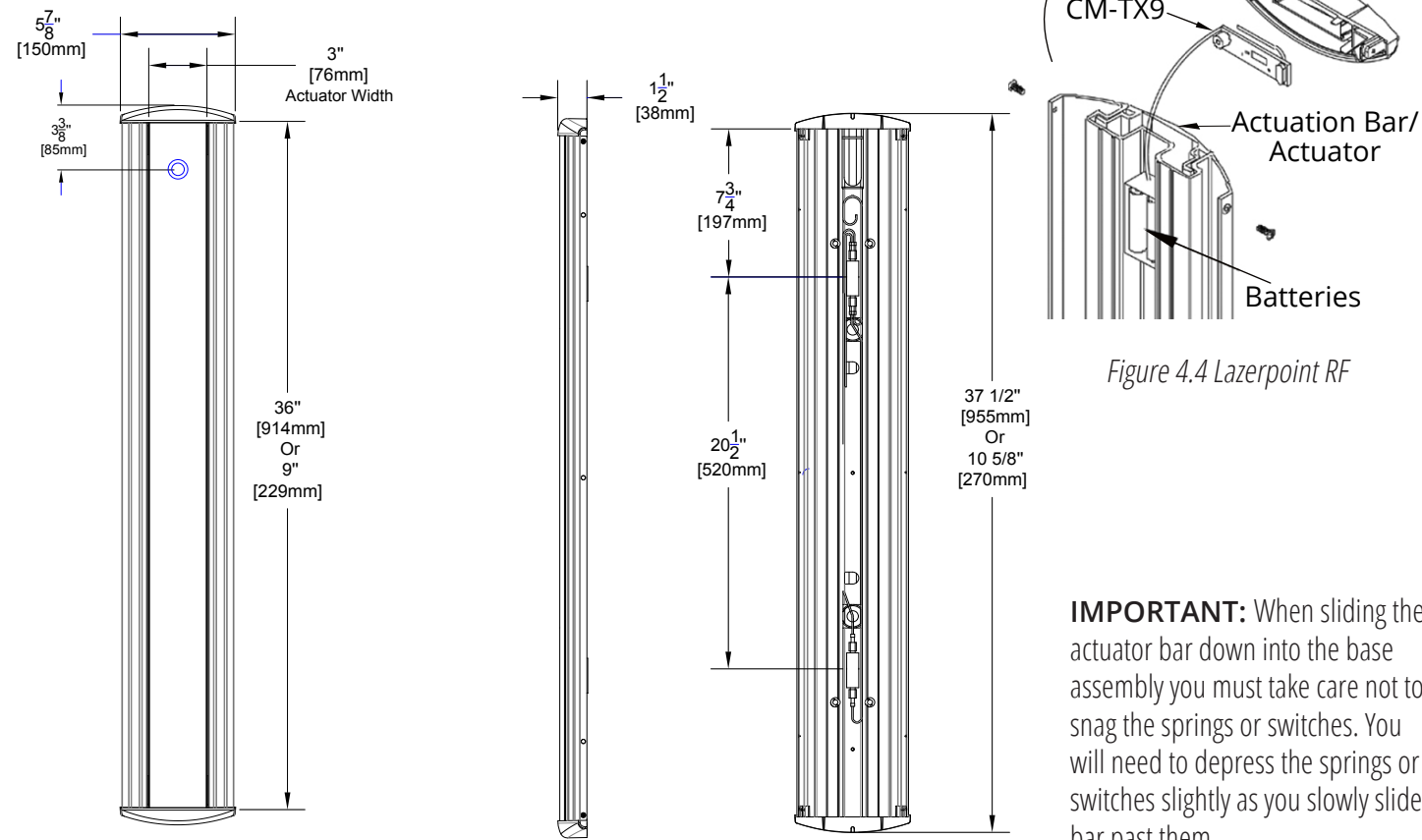

Figure 4.3 Dimensions

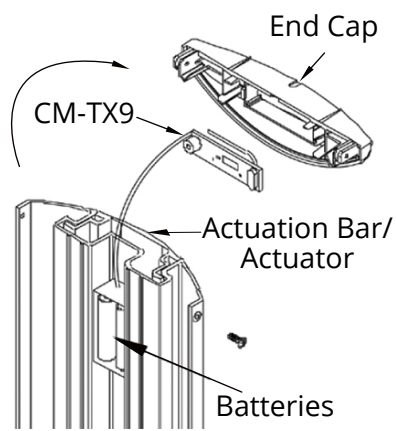

Figure 4.4 Lazerpoint RF

**IMPORTANT:** When sliding the actuator bar down into the base assembly you must take care not to snag the springs or switches. You will need to depress the springs or switches slightly as you slowly slide bar past them.

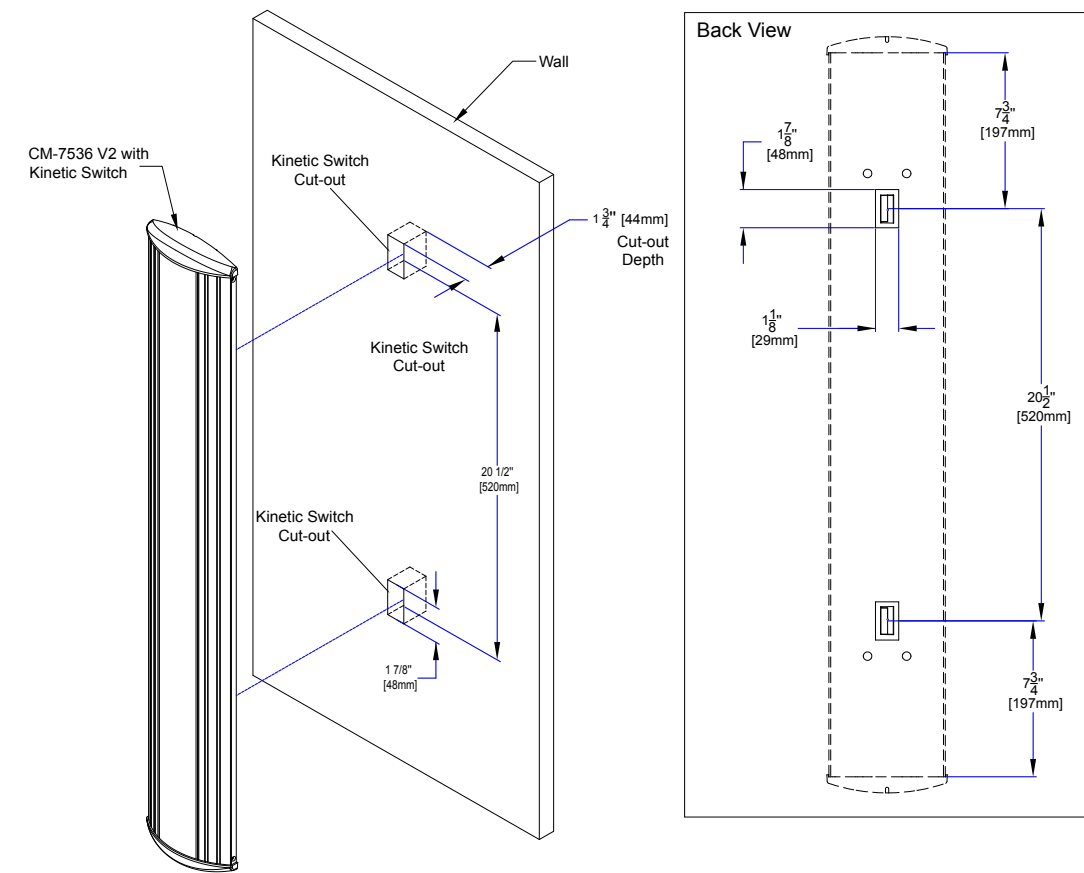

Figure 4.5 Kinetic Wall Mounting

**5. FCC COMPLIANCE INFORMATION**

(If using Kinetic by Camden™)

FCC ID: 2A4GFAGIM5002

This device complies with Part 15 of the FCC Rules. Operation is subject to the following two conditions:

- This device may not cause harmful interference, and
- This device must accept any interference received, including interference that may cause undesired operation.

This equipment has been tested and found to comply with the limits for a Class B digital device, pursuant to Part 5 of the FCC Rules. These limits are designed to provide reasonable protection against harmful interference in a residential installation. This equipment generates, uses and can radiate radio frequency energy and, if not installed and used in accordance with the instructions, may cause harmful interference to radio communications. However, there is no guarantee that interference will not occur in a particular installation. If this equipment does cause harmful interference to radio or television reception, which can be determined by turning the equipment off and on, the user is encouraged to try to correct the interference by one or more of the following measures:

- Reorient or relocate the receiving.
- Increase the separation between the equipment and receiver.
- Connect the equipment into an outlet on a circuit different from that to which the receiver is connected.
- Consult the dealer or an experienced radio/TV technician for help.

**Caution:** Changes or modifications not expressly approved by manufacturer could void the user's authority to operate the equipment.

IC: 1105A-AFIM5002

This device complies with Industry Canada licence-exempt RSS standards. Operation is subject to the following two conditions:

- This device may not cause interference, and
- This device must accept any interference, including interference that may cause undesired operation of the device.

**6. CX-ED1799L INSTALLATION**

**Note:** The products are intended to be installed in accordance with the installation wiring diagram, mechanical assembly drawings provided with each product, the local authority having jurisdiction (AHJ) and the National Electric Code, NFPA 70. When installed in fail secure mode, the local authority shall be consulted with regard to the use of possible panic hardware to allow emergency exit from the secure area.

The electric door strike shall be installed in such a way and in such a location so as to not impair the operation of an emergency exit device or panic hardware mounted on the door.

1. Check that the door jamb has a cutout that fits the strike assembly. If not, refer to Figure 6.2 for guidance.
2. Follow the instructions in section 7 to connect the wires.
3. Use the 12-24 x 1/2" machine screws provided to mount the strike onto the door jamb.
4. Test the fit of the electric strike in the mortise. If necessary, adjust it until it fits properly.

**ANSI FRAME**

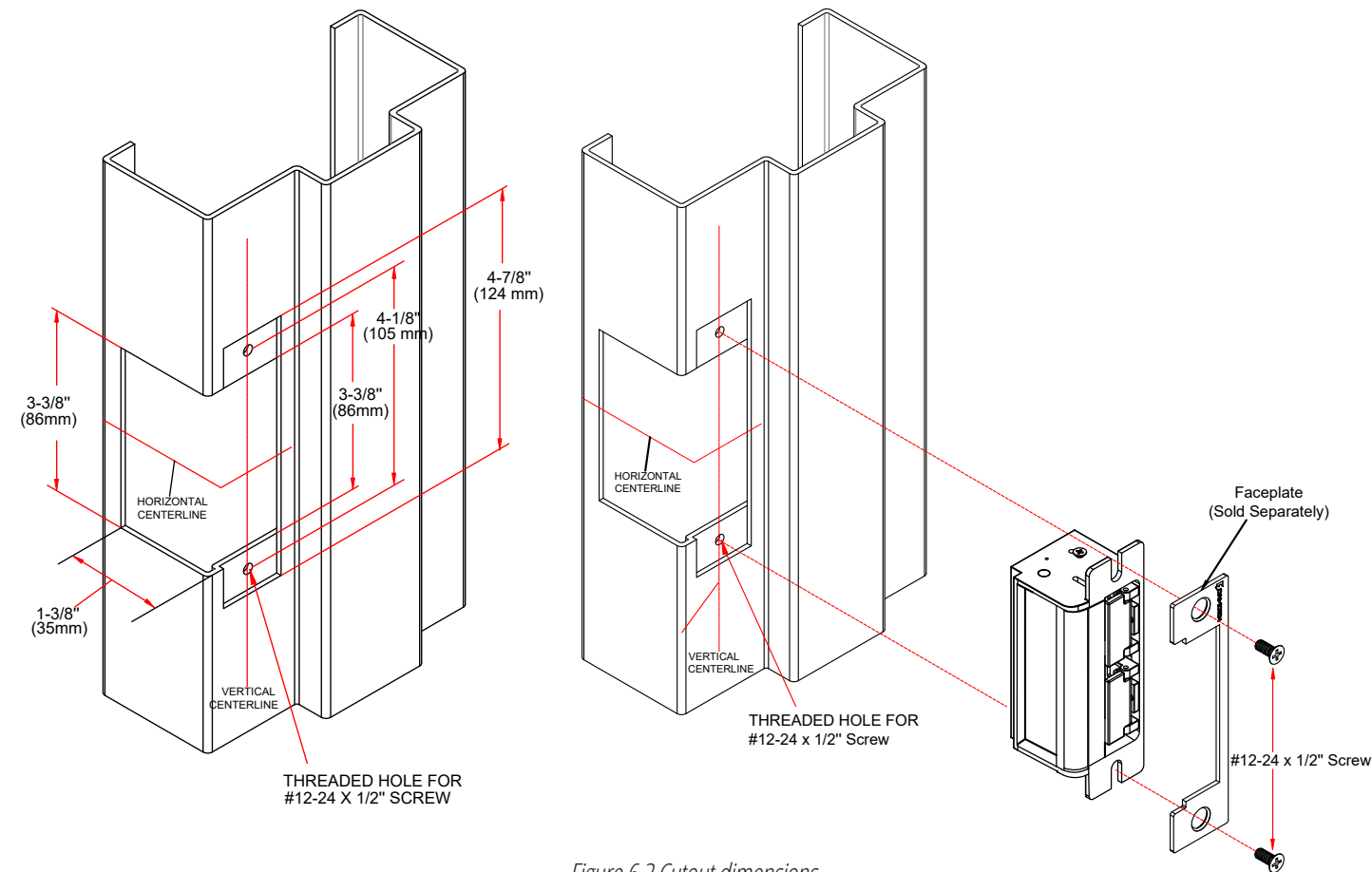
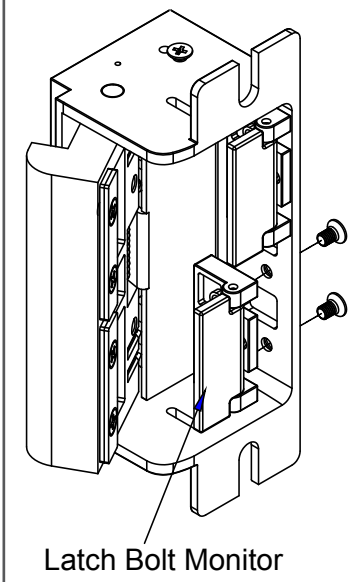

Figure 6.2 Cutout dimensions

**LATCH BOLT INSTALLATION**



**Note:** Figures show typical installation. The dead bolt bracket, can be mounted in alternate locations depending on RH or LH installation.

Figure 6.1 Latch bolt installation

**GAP ADJUSTMENT BETWEEN KEEPER AND LATCH**

The strike comes with four keeper shims included in the package for adjusting the gap between the keeper and latch.

To modify the gap,

1. First loosen and remove the two set screws that secure the keeper shims (see Figure 6.3).
2. Add or remove shims as needed to achieve the desired gap between the latch and keeper.
3. Once the gap is adjusted, securely tighten the two set screws to keep the shims in place.

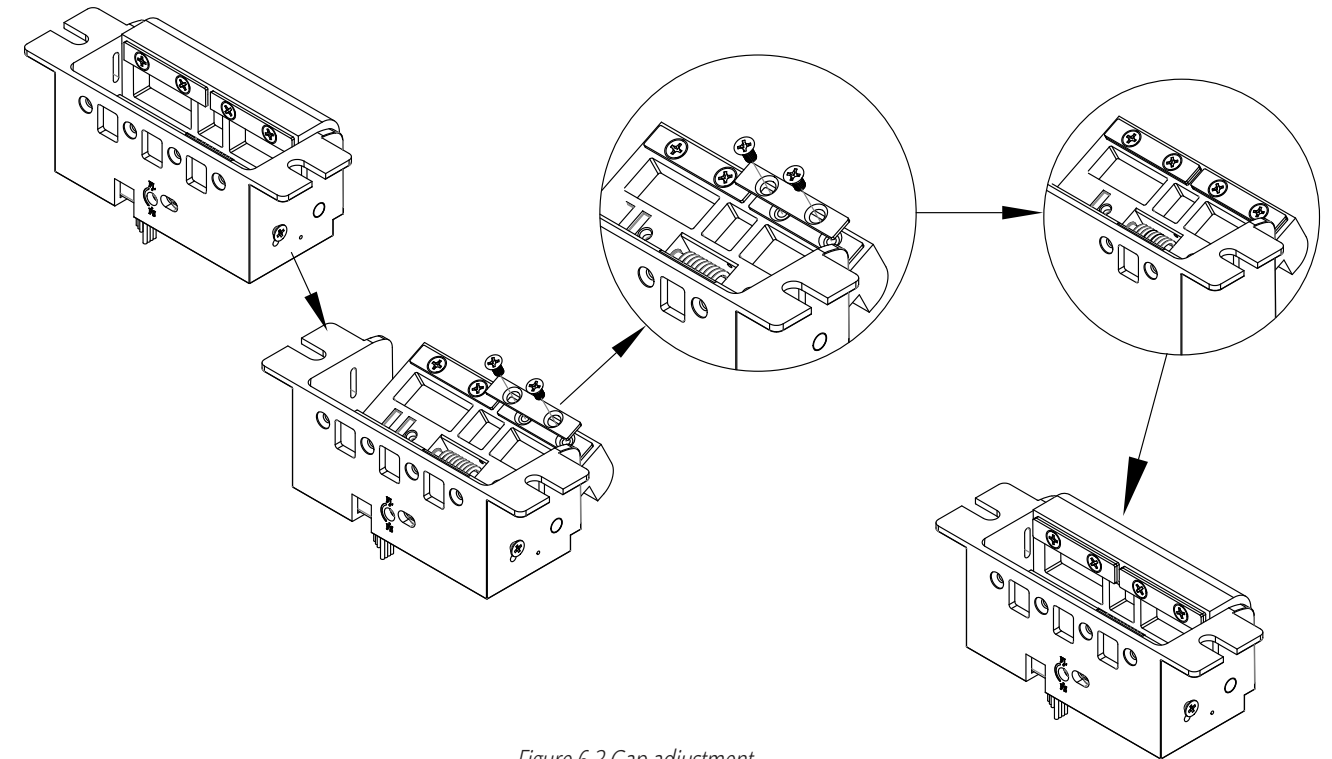

Figure 6.3 Gap adjustment

**DEADBOLT BRACKET INSTALLATION**

1. Place the deadbolt bracket inside the strike opening.
2. Align the key on the bracket to fit the key slot on the strike. Ensure the bracket lock to the strike body.
3. With the screw holes aligned, take the supplied # 4-40 x 3/16" Screws, and tighten the bracket in place.

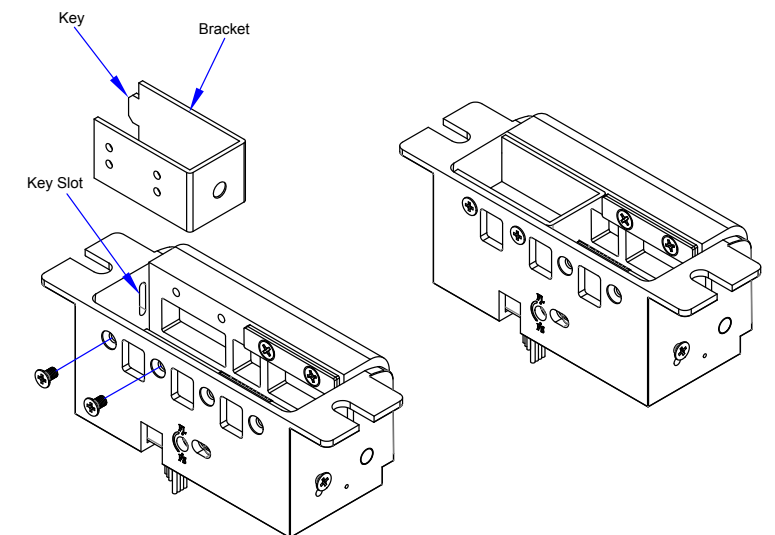

Figure 6.4 Deadbolt bracket installation

**CONNECTION**

POWER	
12VDC	24VDC
Red/Black: +12V	Red: +24
Blue/Green: Ground	Green: Ground

A varistor is provided to protect/prevent strike from spikes. Connect varistor between input wires. (See Figure 6.5)

**Note:** For UL 294 / UL 1034 compliance, the door strikes are to be powered via a UL 294/ UL 603 class 2 power limited output from a control panel and or power supply. Furthermore, when powered by AC/DC the units shall use a UL regulated UL 294/ UL 603 power limited class 2 output rated 12/24V with AC on indicator.

**Latch Bolt Monitor**

This SPST monitor provides position status for the lockset latch bolt. When the latch is engaged, this monitor will provide a contact closure between the COM (white) and NO (purple) wires.

**Strike Monitor Operation**

The Strike Monitor provides status information for the operation of the strike. When the strike is activated this Form C monitor changes state.

**Door Contact**

The provided concealed door contact provides the ability to monitor the status of the door in conjunction with the latch bolt monitor. The door contact can be monitored separately or can be connected in series with the latch bolt monitor. The door contact operates with the same logic as the latch bolt monitors. It provides an OPEN connection when the door is open and a CLOSED connection when the door is closed.

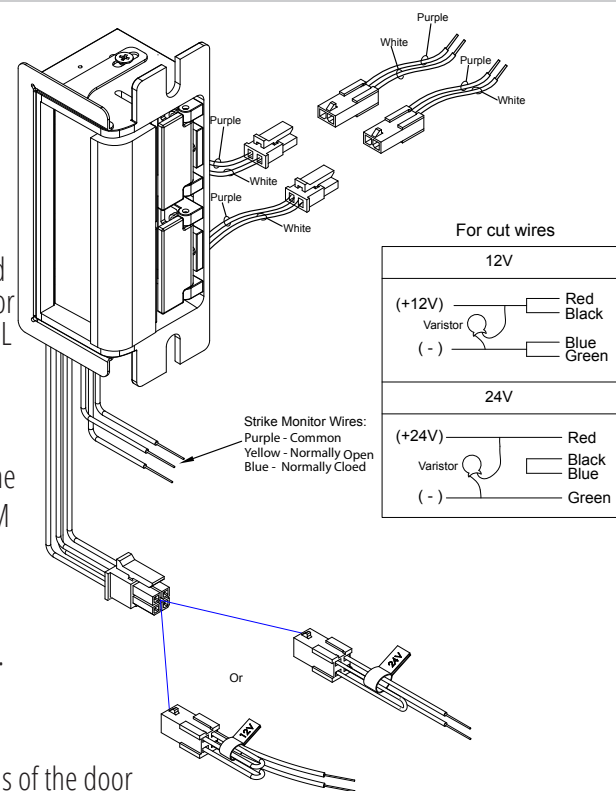

Figure 6.5 Bolt connection options

**OPERATION**

The strike is designed to operate in fail-secure mode by default. However, if needed, it can be changed to fail-safe mode by adjusting the mode screw as follows (See Figure 6.6):

1. Loosen the set screw.
2. Turn the mode screw counterclockwise (CCW) to enable fail-safe mode or clockwise (CW) to enable fail-secure mode.
3. Tighten the set screw.

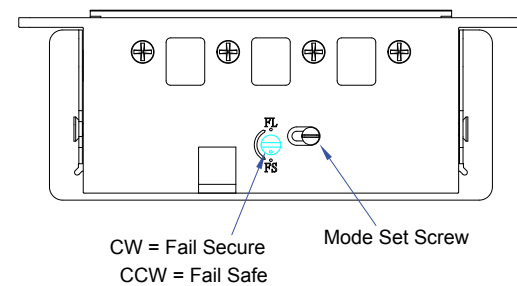

Figure 6.6 Strike operation from Fail Secure to Fail Safe and vice-versa

**7. ORDERING INFORMATION FOR PART REPLACEMENT**

PART NUMBER	DESCRIPTION
60-40E036	WC17-PS Multifunction Relays In Pre-Wired Metal Cabinet
CX-MDA	Magnetic Door Contact
CX-ED1799L	Electric Strike
CM-7536/4-LED	36" Column "Push To Open" Switch
CM-7536/8B-LED	36" Column "Push To Lock" Switch
CM-7536/4	36" Column "Push To Open" Switch

Notes :

- 1.
- 2.
- 3.
- 4.
- 5.
- 6.
- 7.
- 8.
- 9.
- 10.
- 11.
- 12.
- 13.
- 14.
- 15.
- 16.
- 17.
- 18.
- 19.
- 20.
- 21.
- 22.
- 23.
- 24.
- 25.
- 26.

**Questions? Call us toll-free at 1-877-226-3369 or technical support 905-366-3377 (ext. 505)**

### CX-WC17-PS-M1 Wiring Diagram

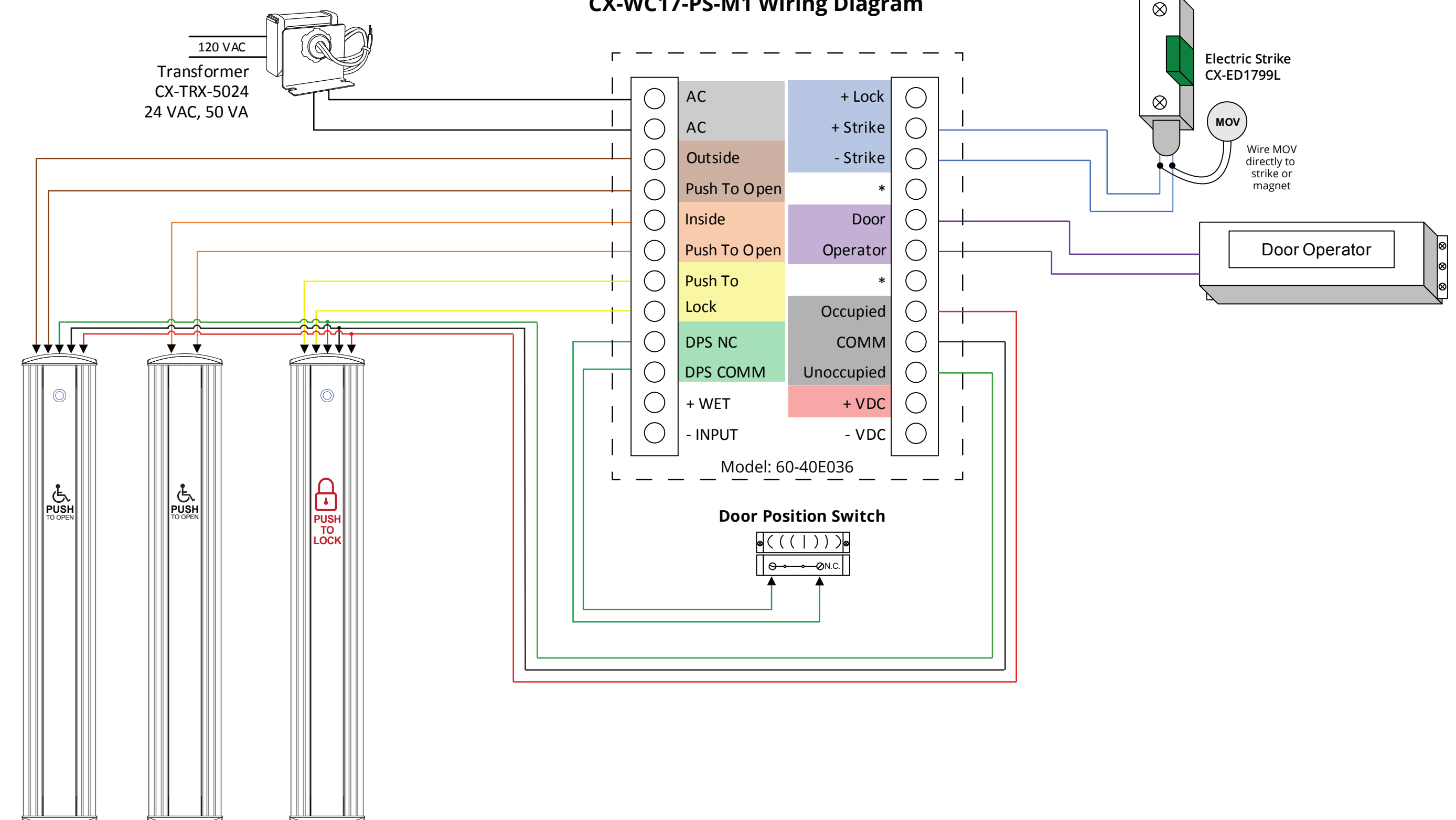

CM-7536/4-LED Outside Push to Open  
 CM-7536/4 Inside Push to Open  
 CM-7536/8B-LED Push to Lock

- Notes**
1. CX-33 can be set to Mode 7 (Normally Unlocked) or Mode 8 (Normally Locked).
  2. Mode 7 = Set Set Strike to Fail Safe.
  3. Mode 8 = Set Strike to Fail Secure.

		<b>CAMDEN DOOR CONTROLS</b>		2395 Skymark Ave, Mississauga, ON L4W 4Y6
SCALE: NONE	DRAWN BY: JML (JF)	DATE: June 4, 2026	REV: 0	
CX-WC17-PS-M1 Wiring Diagram				
DRAWING No: DRG-WC17-PS-M1-1		FILENAME: CX-WC17-PS-M1_7_Wiring Diagram_R1.ai		

### CX-WC17-PS-M1 Wiring Diagram with CX-WEC10-K2 Integration

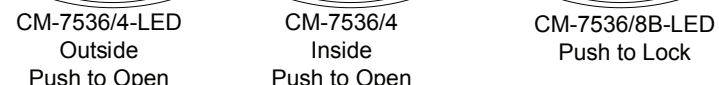
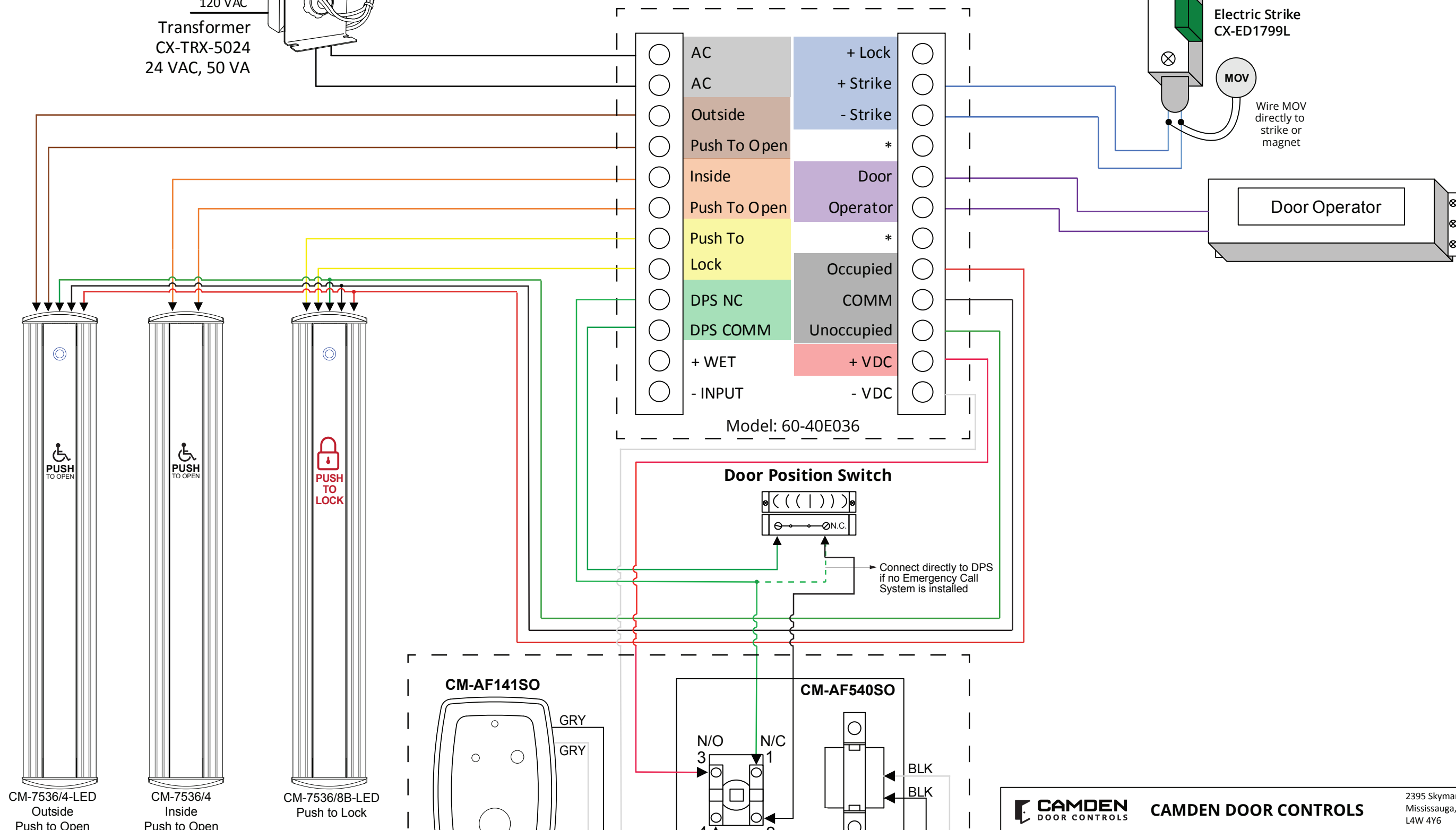
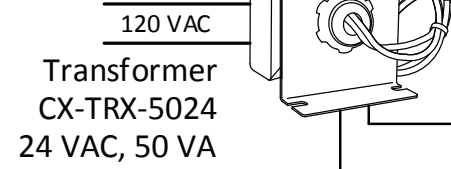

- Notes**
1. CX-33 can be set to Mode 7 (Normally Unlocked) or Mode 8 (Normally Locked).
  2. Mode 7 = Set Set Strike to Fail Safe.
  3. Mode 8 = Set Strike to Fail Secure.

<b>CAMDEN DOOR CONTROLS</b>		2395 Skymark Ave, Mississauga, ON L4W 4Y6	
SCALE: NONE	DRAWN BY: JML (JF)	DATE: June 4, 2026	REV: 0
<b>CX-WC17-PS-M1 &amp; CX-WEC10K2 Wiring Diagram</b>			
DRAWING No: DRG-WC17-PS-M1_WEC10-K2-1		FILENAME: CX-WC17-PS-M1_7_WEC10K2_Wiring Diagram_R1.ai	

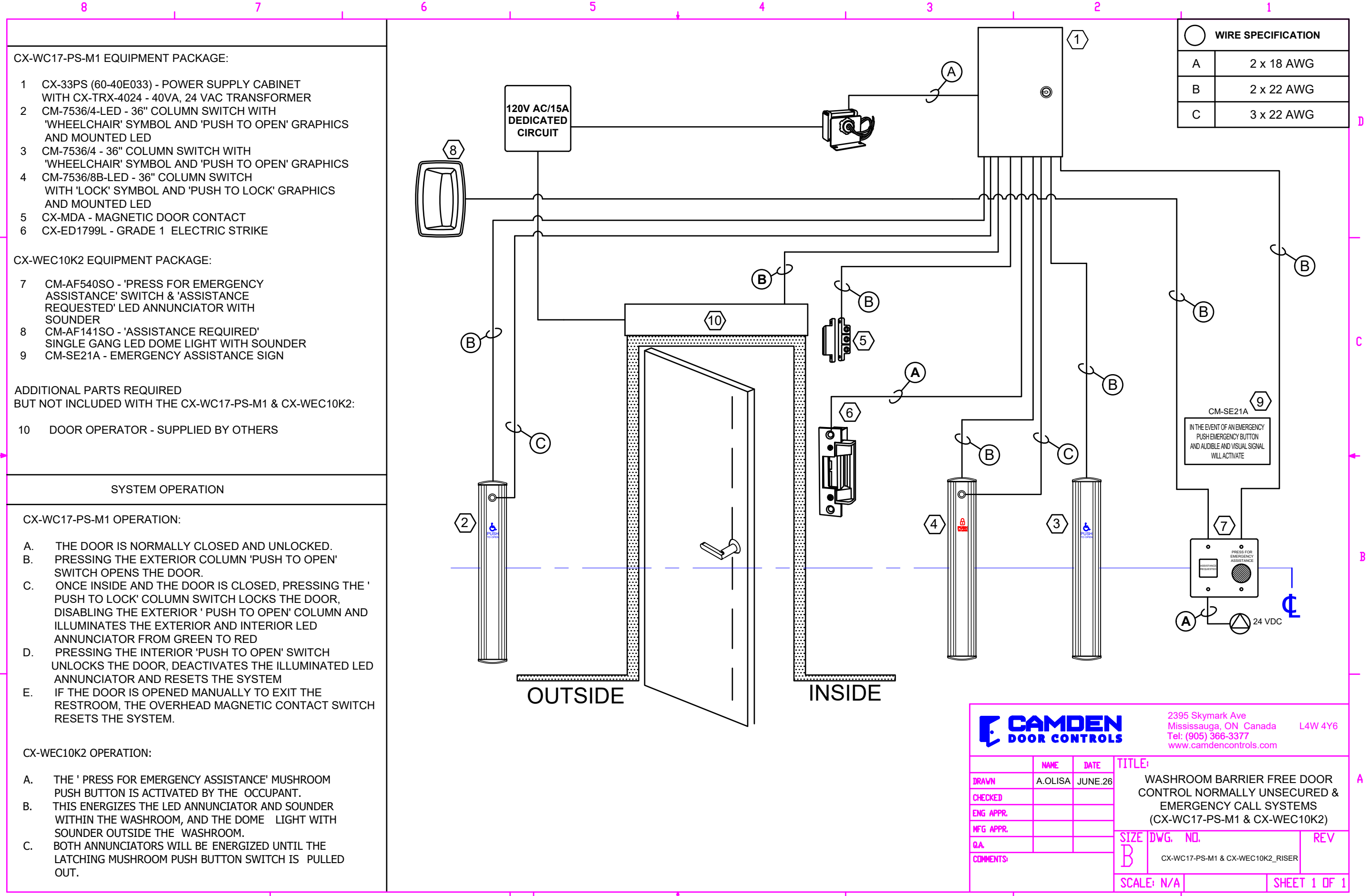

WIRE SPECIFICATION	
A	2 x 18 AWG
B	2 x 22 AWG
C	3 x 22 AWG

- CX-WC17-PS-M1 EQUIPMENT PACKAGE:**
- 1 CX-33PS (60-40E033) - POWER SUPPLY CABINET WITH CX-TRX-4024 - 40VA, 24 VAC TRANSFORMER
  - 2 CM-7536/4-LED - 36" COLUMN SWITCH WITH 'WHEELCHAIR' SYMBOL AND 'PUSH TO OPEN' GRAPHICS AND MOUNTED LED
  - 3 CM-7536/4 - 36" COLUMN SWITCH WITH 'WHEELCHAIR' SYMBOL AND 'PUSH TO OPEN' GRAPHICS AND MOUNTED LED
  - 4 CM-7536/8B-LED - 36" COLUMN SWITCH WITH 'LOCK' SYMBOL AND 'PUSH TO LOCK' GRAPHICS AND MOUNTED LED
  - 5 CX-MDA - MAGNETIC DOOR CONTACT
  - 6 CX-ED1799L - GRADE 1 ELECTRIC STRIKE
- CX-WEC10K2 EQUIPMENT PACKAGE:**
- 7 CM-AF540SO - 'PRESS FOR EMERGENCY ASSISTANCE' SWITCH & 'ASSISTANCE REQUESTED' LED ANNUNCIATOR WITH SOUNDER
  - 8 CM-AF141SO - 'ASSISTANCE REQUIRED' SINGLE GANG LED DOME LIGHT WITH SOUNDER
  - 9 CM-SE21A - EMERGENCY ASSISTANCE SIGN
- ADDITIONAL PARTS REQUIRED BUT NOT INCLUDED WITH THE CX-WC17-PS-M1 & CX-WEC10K2:**
- 10 DOOR OPERATOR - SUPPLIED BY OTHERS

**SYSTEM OPERATION**

- CX-WC17-PS-M1 OPERATION:**
- A. THE DOOR IS NORMALLY CLOSED AND UNLOCKED.
  - B. PRESSING THE EXTERIOR COLUMN 'PUSH TO OPEN' SWITCH OPENS THE DOOR.
  - C. ONCE INSIDE AND THE DOOR IS CLOSED, PRESSING THE 'PUSH TO LOCK' COLUMN SWITCH LOCKS THE DOOR, DISABLING THE EXTERIOR 'PUSH TO OPEN' COLUMN AND ILLUMINATES THE EXTERIOR AND INTERIOR LED ANNUNCIATOR FROM GREEN TO RED
  - D. PRESSING THE INTERIOR 'PUSH TO OPEN' SWITCH UNLOCKS THE DOOR, DEACTIVATES THE ILLUMINATED LED ANNUNCIATOR AND RESETS THE SYSTEM
  - E. IF THE DOOR IS OPENED MANUALLY TO EXIT THE RESTROOM, THE OVERHEAD MAGNETIC CONTACT SWITCH RESETS THE SYSTEM.
- CX-WEC10K2 OPERATION:**
- A. THE 'PRESS FOR EMERGENCY ASSISTANCE' MUSHROOM PUSH BUTTON IS ACTIVATED BY THE OCCUPANT.
  - B. THIS ENERGIZES THE LED ANNUNCIATOR AND SOUNDER WITHIN THE WASHROOM, AND THE DOME LIGHT WITH SOUNDER OUTSIDE THE WASHROOM.
  - C. BOTH ANNUNCIATORS WILL BE ENERGIZED UNTIL THE LATCHING MUSHROOM PUSH BUTTON SWITCH IS PULLED OUT.

		2395 Skymark Ave Mississauga, ON Canada L4W 4Y6 Tel: (905) 366-3377 www.camdencontrols.com	
DRAWN	NAME	DATE	TITLE
CHECKED	A.OLISA	JUNE.26	WASHROOM BARRIER FREE DOOR CONTROL NORMALLY UNSECURED & EMERGENCY CALL SYSTEMS (CX-WC17-PS-M1 & CX-WEC10K2)
ENG APPR.			
MFG APPR.			
QA			
COMMENTS:			
SIZE		DWG. NO.	REV
B		CX-WC17-PS-M1 & CX-WEC10K2_RISER	
SCALE: N/A		SHEET 1 OF 1	