

General Description

CX-EL8000 and CX-EL8000L cabinet locks have been developed to provide easy and affordable locking control. They can be used instead of mechanical locks to prevent unauthorized access to valuables, medicine, or documents.

These compact locking units can be used for locking filing cabinets, fitted cupboards, drawers, glass cabinets, and post-office boxes/safe-deposit boxes.

The simplest way to operate CX-EL8000 locks is via a key switch. If it is necessary to electronically control, register and monitor the access control system, a cabinet lock can be combined with a code or card reader system.

CX-8000L features a change-over contact for monitoring the state of the door (open/closed).

Camden cabinet locks can be operated in the fail-unlocked mode as well as in the fail-locked mode.

Field reversibility is easily achieved by positioning the rosette as required.

The integrated mechanism keeps the door closed, even if it is unlocked. Consequently, additional devices for keeping the door closed (e.g. magnetic snaps) are not required.

Fail-unlocked and fail-locked operation:

In the fail-unlocked mode, power must be applied for the door to be locked. In the fail-locked mode, power must be applied to unlock the door.

Note:

With fail-locked operation, in the event of power failure, the door cannot be opened.

Functional Characteristics

CX-EL8000 and CX-EL8000L consist of two parts. The locking element is mounted laterally to the cabinet. The rosette is installed on the door.

When the door is closed, the locking bolt of the rosette engages the locking element and the cabinet is locked.

CX-EL8000 Series locks can be installed for front or top engagement of the rosette (see illustration 1).

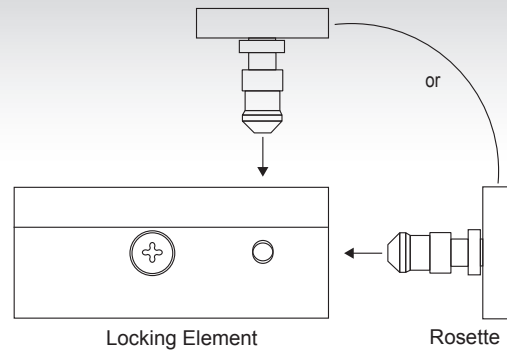

Illustration 1: Locking principle

Setting Fail-unlocked or Fail-locked Operating Mode

Two pictograms are printed on the rosette, one for fail-unlocked and one for fail-locked mode (see illustration 2).

For operation in the fail-unlocked mode, turn the pin so that the mark on the locking element points to the fail-unlocked pictogram. For operation in the fail-locked mode, turn the pin so that the mark points to the fail-locked pictogram.

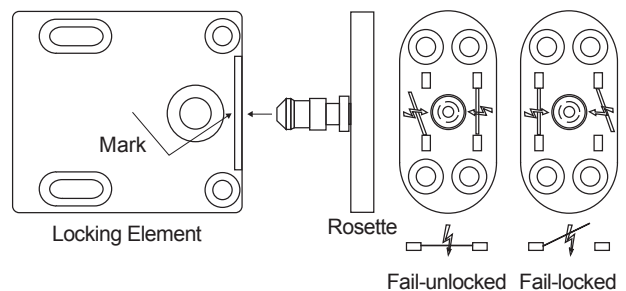

Illustration 2: Alignment of the Rosette

Mounting



Mount and adjust the cabinet lock only when the rosette is in the fail unlocked position, in case the lock cannot be unlocked electrically. Otherwise, the door or drawer cannot be opened.

Four cylindrically countersunk mounting holes are provided for mounting the locking element as well as the rosette.

For position of mounting holes, please see drawing. Reducing bushings, screws and washers are included in the hardware kit supplied with the unit.

Dimensional Drawing:

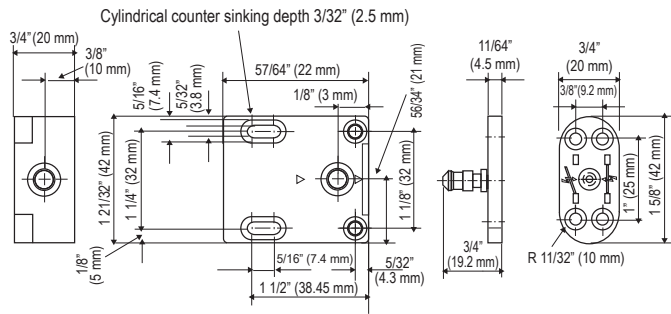

Illustration 3: Dimensional Drawing

Mounting Instructions

The locking element and rosette must be aligned as shown in illustration 4 (flush).

When closing the door or drawer, the locking bolt of the rosette must be able to engage the locking element without being obstructed. When closed, the door or drawer should not be jammed against the lock.

The rosette can be surface mounted but is also suitable for flush mounting. Horizontal adjustment of the lock is done by means of the elongated holes in the locking element.

Double sided adhesive tape is supplied, which can be attached to the back of the rosette.

After fixing the adhesive tape, the rosette must be put into the mounted locking element and the door must be closed. When the door is opened again the rosette sticks in the correct position. After marking the drilling points, the rosette must be turned through 180°.



Do not mount the rosette as shown in illustration 5 i.e. turned through 90°. If the locking bolt of the rosette engages the lock this way, it will not be possible to open the door or drawer.

Correct Positioning: The locking bolt of the rosette engages the locking element without interference.

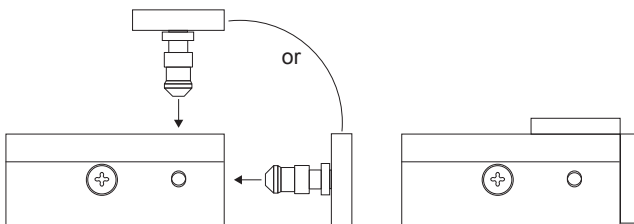

Illustration 4: Mounting Instruction

Wrong Positioning: The rosette turned - through 90°.

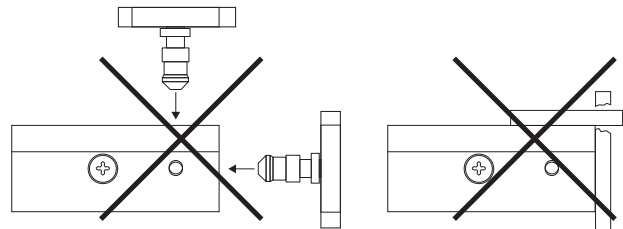

Illustration 5: Mounting Instruction

Mounting Examples

Illustrations 6 and 7 show possibilities for mounting the cabinet lock to a desk with drawers or to a cupboard.

The product package contains fixing screws and washers for the locking element and the rosette, as well as reducing bushings for the installation in existing bore holes.

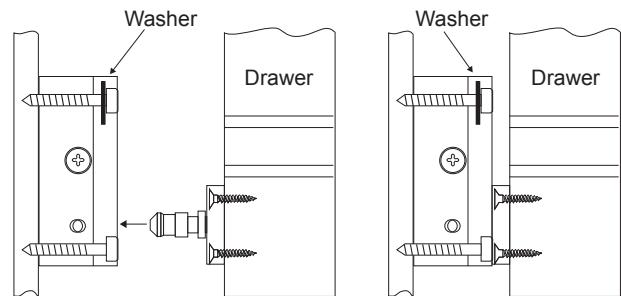
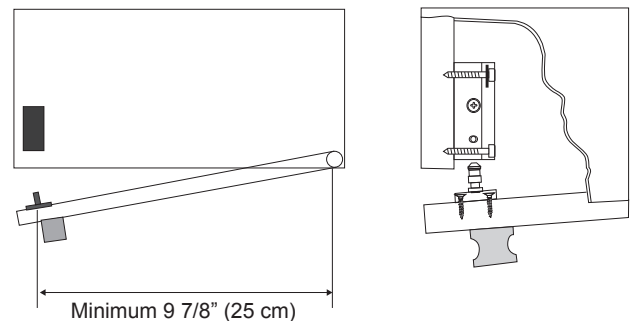

Illustration 6: Mounting to a Drawer



Illustrator 7: Mounting to a Fitted Cupboard

Electrical Connections

For continuous duty operation, CX-EL8000 locks must be operated with a regulated power supply 12/24V DC. While the locks may be operated on AC, buzzing will occur when energized. Connections as per the wiring diagram following (see Illustration 8).

Jumpers as well as diodes are included in the product packaging.

CX-EL8000L has a contact (door position switch), which monitors the door or drawer position (open/closed)

When determining the wiring, ensure that the supply voltage – measured at the terminals – exceeds the minimum indicated.

Wiring Diagram

Loosen the screws of the required terminals by turning them counterclockwise (3-4 turns). Insert the lead into the terminal. Retighten the screws by turning them clockwise.

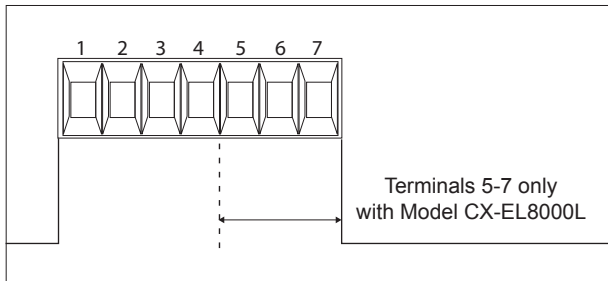

***Only with DC!**

If the cabinet lock is DC powered, an additional diode must be connected in parallel to the coil.



Diode Product Package

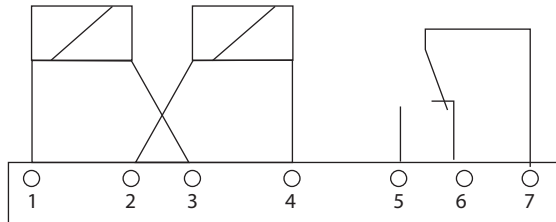

Only with CX-EL8000L
Contact position shows "Door Open"

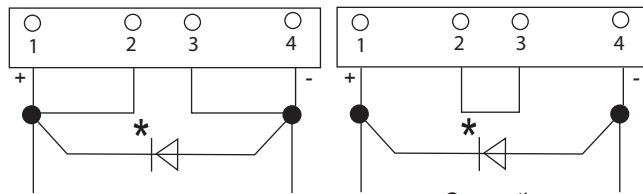

Connection with 12V

Connection with 24V

Illustration 8: Power Connection

Technical Data

Modes of Operation	Fail-unlocked or fail-locked operation. Momentary or continuous unlocking.			
Operating Voltage	12V DC Stab.	12V AC buzzing	24V DC stab.	24V AC buzzing sound
Connecting Voltage	Operating voltage + - 10%			
Current Consumption Typ.	260 mA	140 mA	130 mA	70 mA
Contact Rating	1 amp@25V			
Holding Force	1000 N (≈100 kp)			
Type of Protection According to DIN 40050	IP 20			
Housing Temperature	Continuous energization: approx. 140°F (60°C)			
Temperature Rating	50° to 104°F (+10°C - +40°C)			
Lock Dimensions	1.9" L x 1.7" W x 3/4" H (48 mm x 42 mm x 20 mm)			



Push Buttons



Key Pads



Strikes



Magnetic Locks



Key Switches



Relays & Timers



Access Control



DISCOVER THE BEST IN DOOR ACTIVATING AND LOCKING PRODUCTS!

www.camdencontrols.com
Toll Free: 1.877.226.3369

File: CX-EL8000 & CX-EL8000L Installation Instructions
Revised: Sept. 01, 2010
Part No.: 40-82B117